

■ 型号说明 Model Code

A2F	O	28	/	6	1	R	—	V	P	B	05	
01	02	03		04	05	06		07	08	09	10	11

01	斜轴式结构, 定量柱塞单元 Bent-axis design, fixed																JA2F	
02	马达 Motor																M	
	泵 Pump																O	
03	排量 Displacement mL/r	10	12	16	23	28	32	45	56	63	80	90	107	125	160	180		
		√	√	√	√	√	√	√	√	√	√	√						
04	系列 Series																6	
05	标号 Index																1	
06	旋转方向 Directions of rotation	双向 bidirectional																W
		正转 clockwise																R
		反转 counter-clockwise																L
07	密封 Seals	氟橡胶 FKM																V
		丁腈橡胶 NBR																P
08	轴伸 Drive shafts	花键轴 Splined shaft DIN 5480	10	12	16	23	28	32	45	56	63	80	90	107	125	160	180	
			√	√	√	√	√	√	√	√	√	√	√					
		平键轴 Parallel keyed shaft DIN 6885	10	12	16	23	28	32	45	56	63	80	90	107	125	160	180	
			√	√	√	√	√	√	√	√	√	√	√					
09	安装法兰 4孔 Mounting flanges (ISO 4-hole)	10	12	16	23	28	32	45	56	63	80	90	107	125	160	180		
		√	√	√	√	√	√	√	√	√	√	√						B
10	后盖油口 Port plates	SAE 法兰油口 ; A 和 B 在后侧 Ports A and B SAE, at rear end				√	√	√	√	√	√	√					01	
		SAE 法兰油口 ; A 和 B 在两侧, 相对 Ports A and B SAE, opposite side				√	√	√	√	√	√	√					02	
		螺纹油口 ; A 和 B 在两侧, 相对 Ports A and B threads, opposite side	√	√	√	√	√	√										03
		螺纹油口 ; A 和 B 在两侧和后侧 Ports A and B threads, at side and rear end	√	√	√	√	√	√	√	√	√							04
		SAE 法兰油口 ; A/B 侧面 ; S 后面 SAE flange port, A/B at side and S at rear				√	√	√	√	√	√	√	√					05
		侧面螺纹油口 A/B 和后侧螺纹油口 S Threaded port, A/B at side and S at rear	√	√	√													06
11	阀 valves	无 Void (A2FO)																
		不带阀 without valves(A2FM)																0

结构剖视 Construction

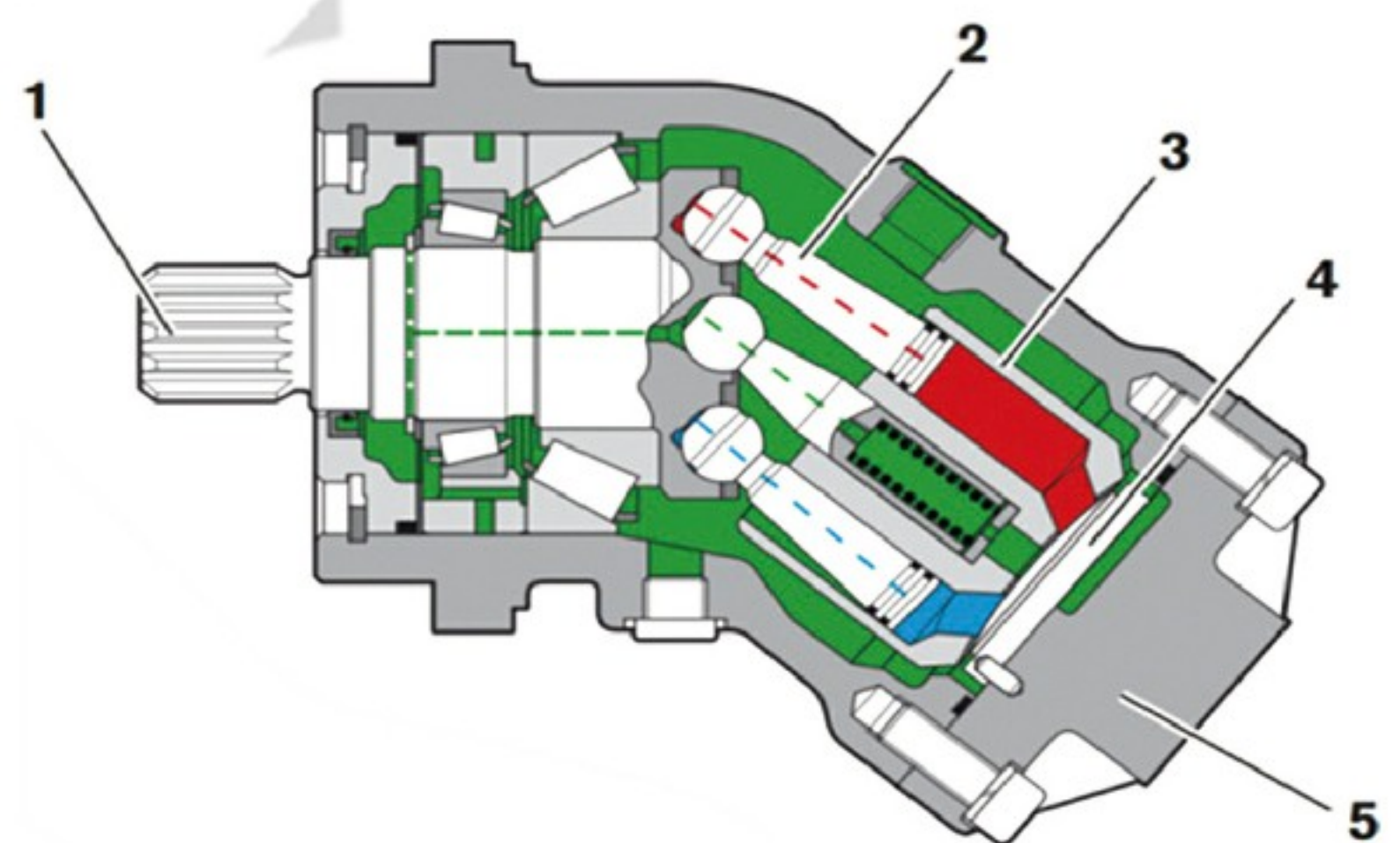

- 1. 传动轴 Drive shaft
- 2. 柱塞 Piston
- 3. 缸体 Cylinder
- 4. 配油盘 Control plate
- 5. 后盖 Port plate

外形尺寸 Dimension

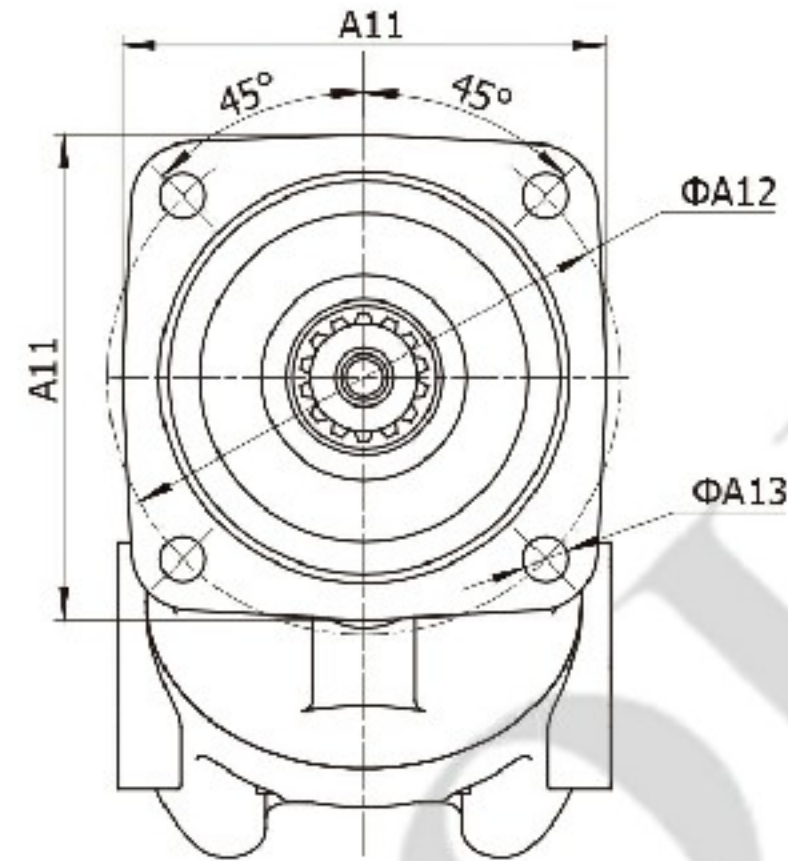
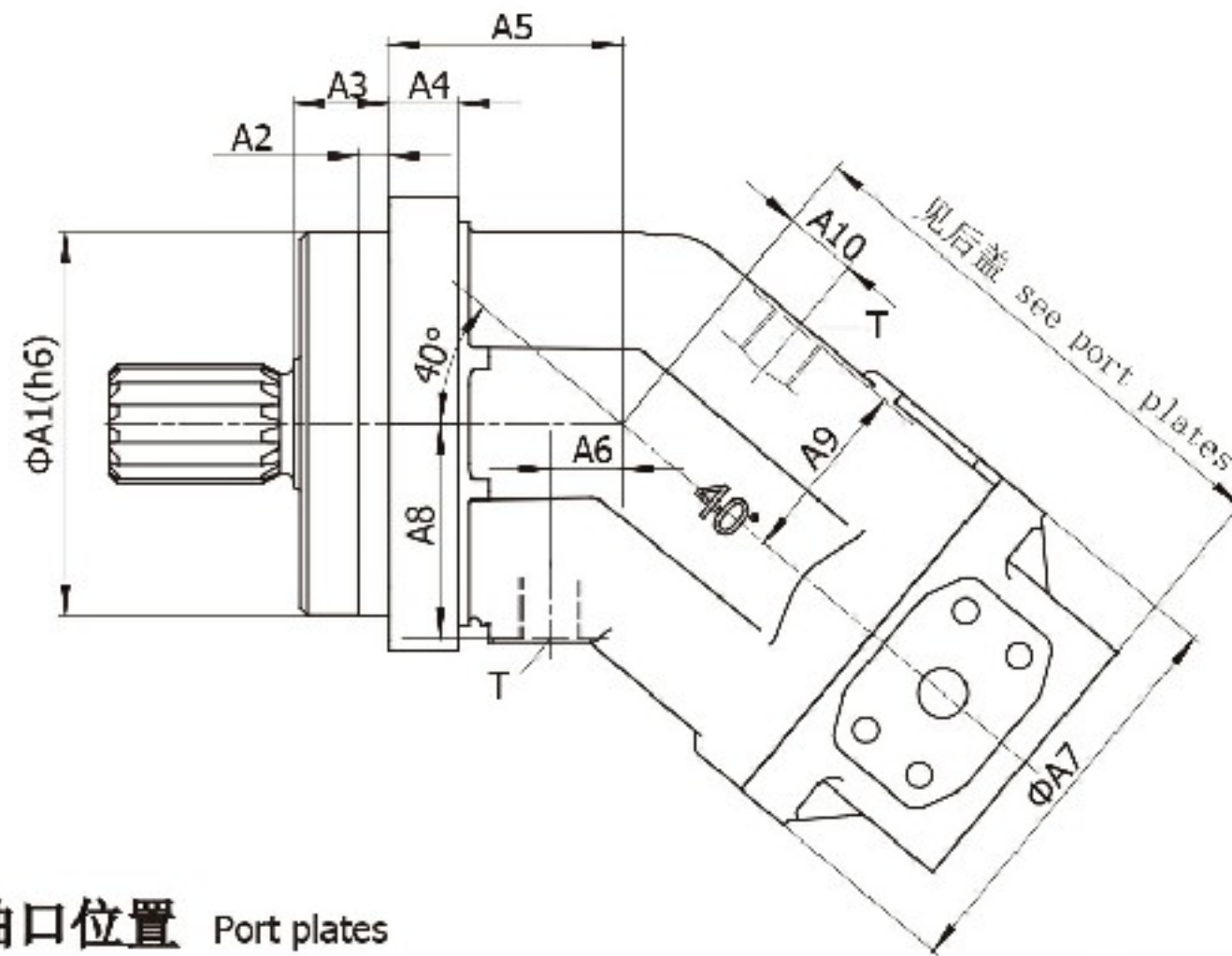

后盖油口位置 Port plates

01 SAE法兰油口;A和B在后侧
Ports A and B SAE, at rear end

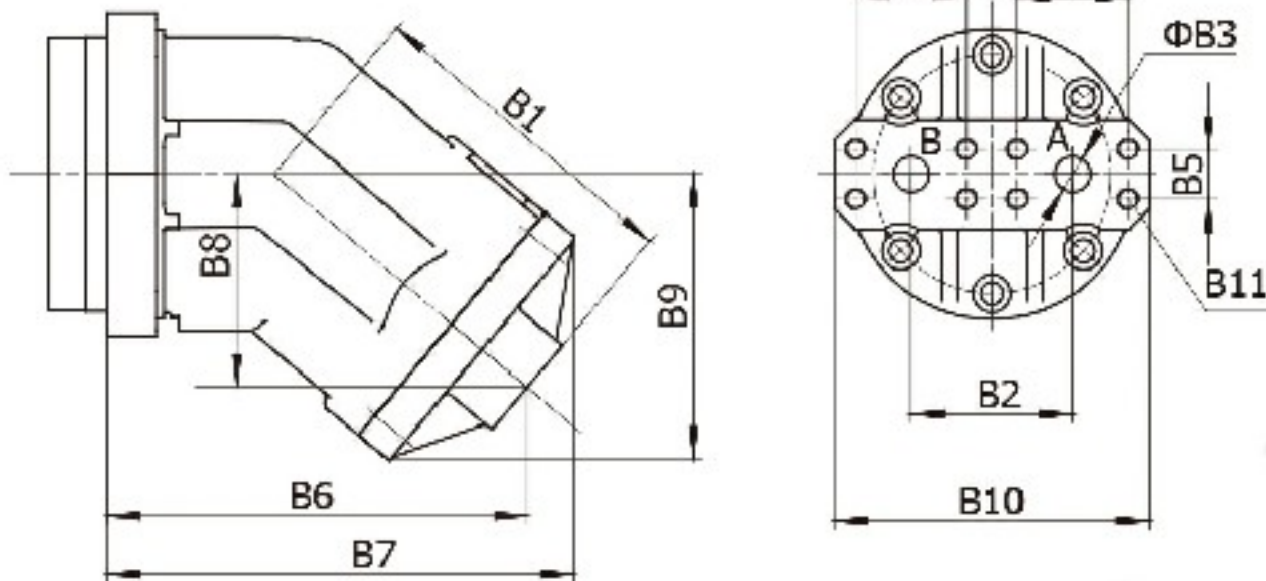

02 SAE法兰油口;A和B在两侧,相对 (Standard for Motor)
Ports A and B SAE, opposite side

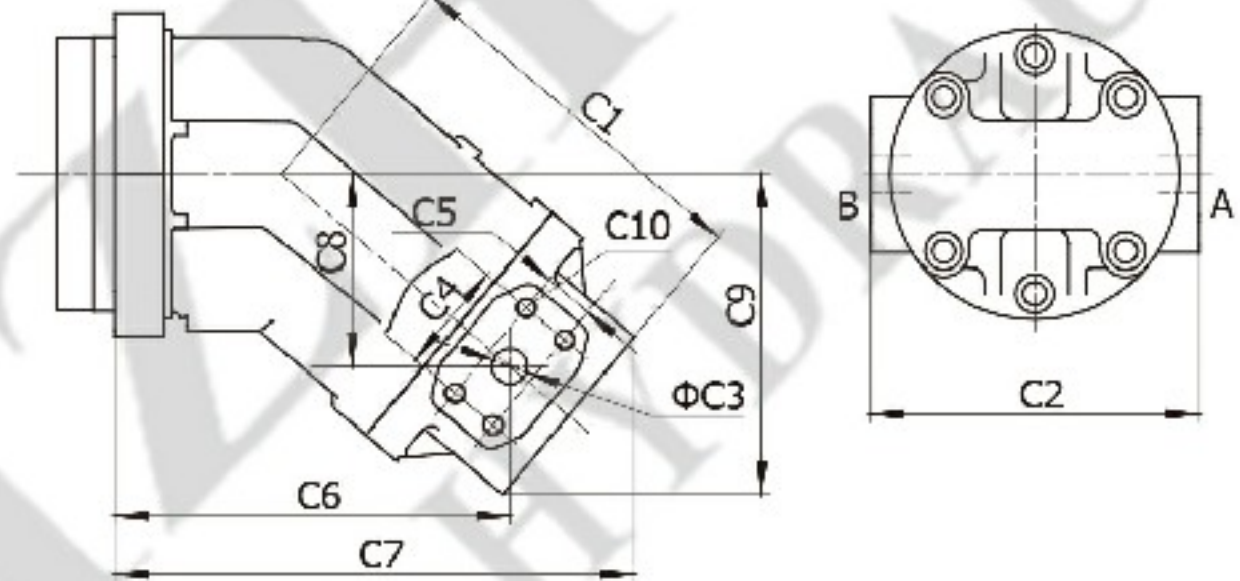

03 螺纹油口;A和B在两侧,相对
Ports A and B threads, at side, opposite side

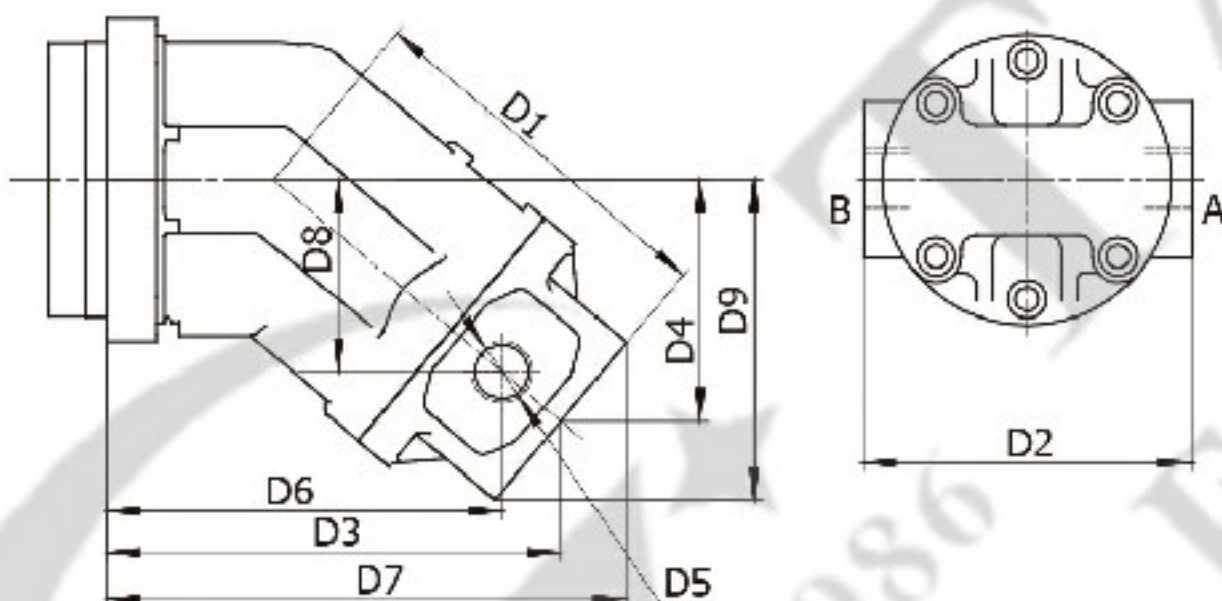

04 螺纹油口;A和B在两侧和后侧
Ports A and B threads, at side and rear end

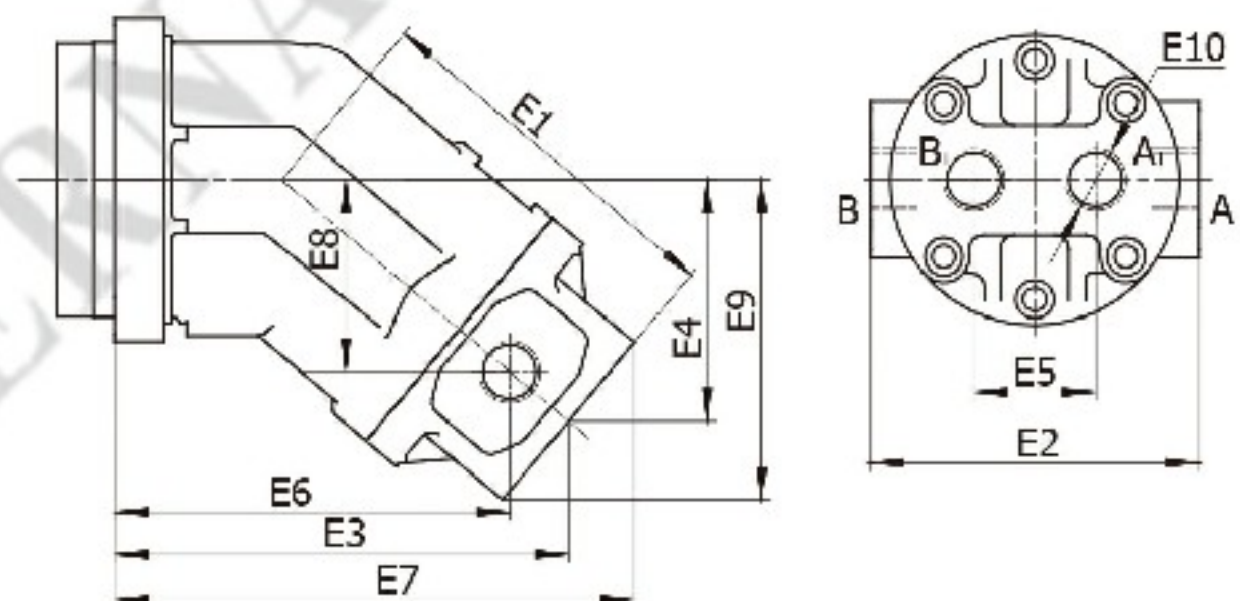

05 SAE法兰油口;A/B侧面;S后面 (Standard for Pump)
SAE flange port, A/B at side and S at rear

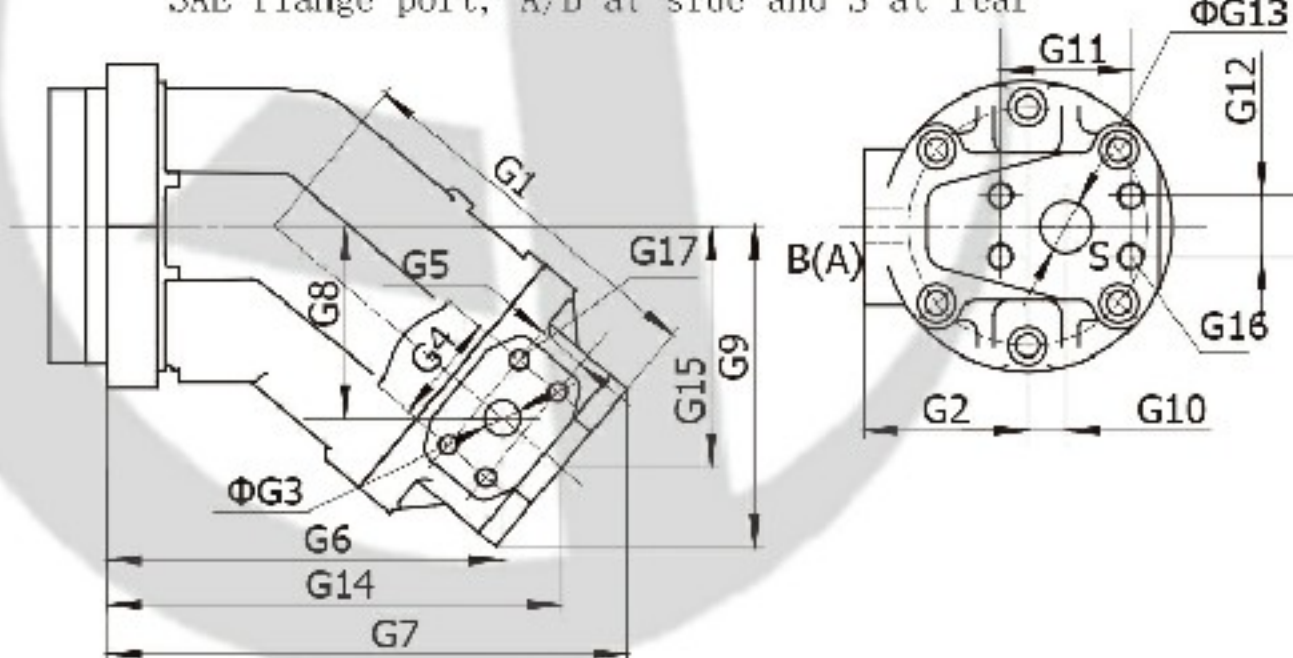

06 侧面螺纹油口 A/B 和后侧螺纹油口 S
Threaded port, A/B at side and S at rear

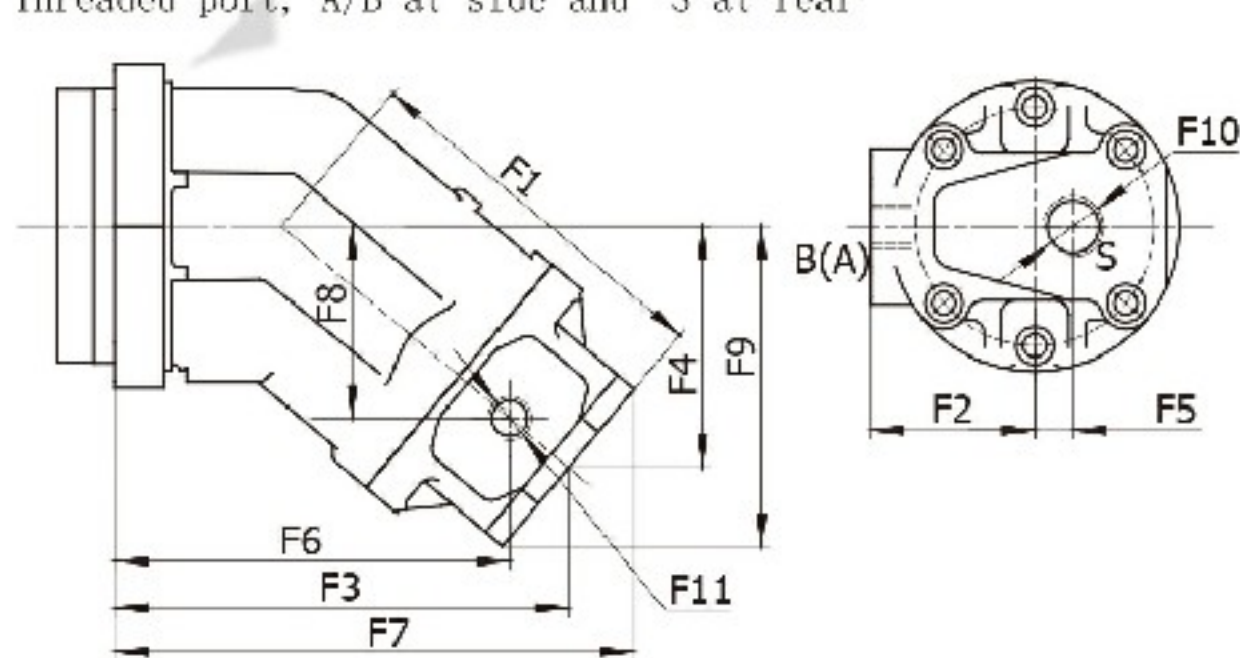

轴伸 Drive shafts

A 花键轴 DIN 5180
Splined shaft

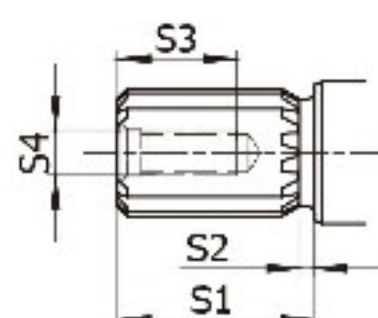

Z 花键轴 DIN 5180
Splined shaft

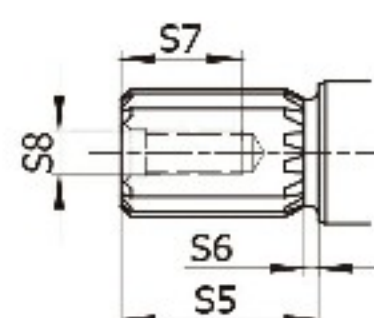

B 平键轴 DIN 6885
Parallel keyed shaft

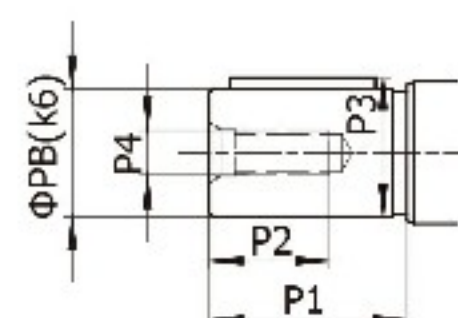

P 平键轴 DIN 6885
Parallel keyed shaft

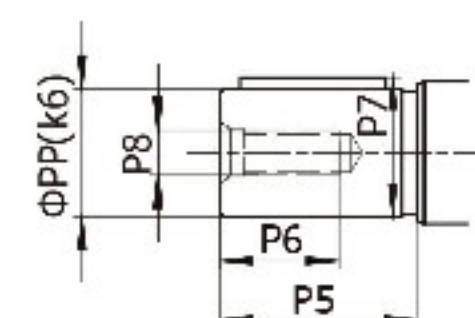

■ 外形尺寸 Dimension

规格 Size	A1	A2	A3	A4	A5	A6	A7	A8	A9	A10	A11	A12	A13	T	B1	B2	B3	B4	B5
10,12,16	Φ80	6	20	12	64.5	5	Φ85	53.5	41.5	5	95	Φ100	Φ9	M12x1.5	/	/	/	/	/
23,28,32	Φ100	8	25	18	60.7	19	Φ106	55.5	48.5	19	118	Φ125	Φ11	M16x1.5	121	59	Φ13	40.5	18.2
45	Φ125	12	32	20	60.3	18	Φ118	63	52	18	150	Φ160	Φ13.5	M18x1.5	138	75	Φ19	50.8	23.8
56,63	Φ125	10	32	20	67.5	18	Φ128	70	56	18	150	Φ160	Φ13.5	M18x1.5	149.5	75	Φ19	50.8	23.8
80,90	Φ140	10	32	20	78.5	15	Φ138	83	61	15	165	Φ180	Φ13.5	M18x1.5	162.5	84	Φ25	57.2	27.8
107,125	Φ160	10	40	23	82.8	18	Φ150	85	67	18	190	Φ200	Φ17.5	M18x1.5	186.5	99	Φ32	66.7	31.8
160,180	Φ180	10	40	25	93	19.5	Φ180	95.5	77.5	19.5	210	Φ224	Φ17.5	M22x1.5	208	99	Φ32	66.7	31.8

规格 Size	B6	B7	B8	B9	B10	B11	C1	C2	C3	C4	C5	C6	C7	C8	C9	C10	D1	D2
10,12,16	/	/	/	/	/	/	/	/	/	/	/	/	/	/	/	/	108	85
23,28,32	153	173	78	106	115	M8;15 deep	137	120	Φ13	40.5	18.2	144	190	70	117	M8;15 deep	137	120
45	166	194	89	122	147	M10;17 deep	155	128	Φ19	50.8	23.8	155	207	80	133	M10;17 deep	/	/
56,63	182	206	96	130	147	M10;17 deep	166.5	136	Φ19	50.8	23.8	171	225	87	142	M10;17 deep	/	/
80,90	203	233	104.5	145	166	M12;17 deep	189.5	160	Φ25	57.2	27.8	196	257	99	162	M12;17 deep	/	/
107	225.5	252	120	159	194	M14;19 deep	222	178	Φ25	57.2	27.8	213	285	110	181	M12;17 deep	/	/
125	225.5	252	120	159	194	M14;19 deep	222	178	Φ32	66.7	31.8	213	285	110	181	M14;19 deep	/	/
160,180	252	294	134	188	194	M14;19 deep	233	202	Φ32	66.7	31.8	237	294	121	188	M14;19 deep	/	/

规格 Size	D3	D4	D5	D6	D7	D8	D9	E1	E2	E3	E4	E5	E6	E7	E8	E9	E10	G1
10,12,16	147	69.5	M22x1.5	130.5	166	55.5	91	108	85	147	69.5	34	130.5	166	55.5	91	M22x1.5	/
23,28,32	166	88	M27x2	144	190	70	117	137	120	166	88	58	144	190	70	117	M27x2	141
45	/	/	/	/	/	/	/	155	128	179	100	58	155	207	80	133	M33x2	158
56,63	/	/	/	/	/	/	/	166.5	136	195	107	58	171	225	87	142	M33x2	169.5
80,90	/	/	/	/	/	/	/	/	/	/	/	/	/	/	/	/	/	189.5
107,125	/	/	/	/	/	/	/	/	/	/	/	/	/	/	/	/	/	212
160,180	/	/	/	/	/	/	/	/	/	/	/	/	/	/	/	/	/	233

规格 Size	G2	G3	G4	G5	G6	G7	G8	G9	G10	G11	G12	G13	G14	G15	G16	G17	F1	F2
10,12,16	/	/	/	/	/	/	/	/	/	/	/	/	/	/	/	/	108	42.5
23,28,32	60	Φ13	40.5	18.2	144	193	70	120	14	47.6	22.2	Φ19	169	91	M10;17 deep	M8;17 deep	/	/
45	63.5	Φ19	50.8	23.8	155	206	80	132	20	52.4	26.2	Φ25	181	102	M10;17 deep	M10;17 deep	/	/
56,63	68	Φ19	50.8	23.8	171	225	87	142	23	52.4	26.2	Φ25	197	109	M10;17 deep	M10;17 deep	/	/
80,90	73	Φ25	57.2	27.8	196	255	99	160	25	58.7	30.2	Φ32	223.5	122	M10;17 deep	M12;17 deep	/	/
107	89	Φ25	57.2	27.8	213	275	110	173	20	69.9	35.7	Φ38	245	136	M12;20 deep	M12;17 deep	/	/
125	89	Φ32	66.7	31.8	213	275	110	173	20	69.9	35.7	Φ38	245	136	M12;20 deep	M14;19 deep	/	/
160,180	101	Φ32	66.7	31.8	237	294	121	188	15	69.9	35.7	Φ42	271	150	M12;20 deep	M14;19 deep	/	/

规格 Size	F3	F4	F5	F6	F7	F8	F9	F10	F11	A shaft	S1	S2	S3	S4	B shaft
10,12,16	147	69	16	130.5	167.5	55.5	93.5	M33x2	M22x1.5	W25x1.25x18x9g	28	6	22	M10	key 8x7x32
23,28,32	/	/	/	/	/	/	/	/	/	W30x2x14x9g	35	8	22	M10	key 8x7x40
45	/	/	/	/	/	/	/	/	/	W32x2x14x9g	35	8	28	M12	/
56,63	/	/	/	/	/	/	/	/	/	W35x2x16x9g	40	8	28	M12	key 10x8x50
80,90	/	/	/	/	/	/	/	/	/	W40x2x18x9g	45	8	36	M16	key 12x8x56
107,125	/	/	/	/	/	/	/	/	/	W45x2x21x9g	50	8	36	M16	key 14x9x63
160,180	/	/	/	/	/	/	/	/	/	W50x2x24x9g	55	11	36	M16	key 14x9x70

规格 Size	PB	P1	P2	P3	P4	Z shaft	S5	S6	S7	S8	P shaft	PP	P5	P6	P7	P8
10,12,16	Φ25	40	22	28	M10	W20x1.25x14x9g	34	12	16	M6	key 6x6x32	Φ20	40	16	22.5	M6
23,28,32	Φ30	50	22	33	M10	W25x1.25x18x9g	43	15	19	M8	key 8x7x40	Φ25	50	19	28	M8
45	/	/	/	/	/	W30x2x14x9g	35	8	28	M12	key 8x7x50	Φ30	60	28	33	M12
56,63	Φ35	60	28	38	M12	W30x2x14x9g	35	8	28	M12	key 8x7x50	Φ30	60	28	33	M12
80,90	Φ40	70	36	43	M16	W35x2x16x9g	40	8	28	M12	key 10x8x56	Φ35	70	28	38	M12
107,125	Φ45	80	36	48.5	M16	W40x2x18x9g	45	8	28	M12	key 12x8x63	Φ40	80	28	43	M12
160,180	Φ50	90	36	53.5	M16	W45x2x21x9g	50	8	36	M16	key 14x9x70	Φ45	90	36	48.5	M16