

# Variable Displacement Vane Pump

變量葉片泵系列

## VCM-SF/SM/SFC



SF-12/20



SF-30/40



SFC-30/40

油壓記號

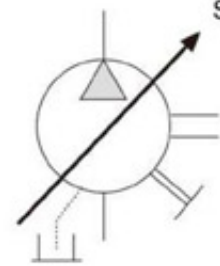

SYMBOL



SM-30/40

### 型式號碼 / MODEL CODE

VCM - SF - 20 - B - 10 - ※

#### 鍵型 (Button to select)

參照 PAG.2 10 項

#### 設計號碼 Design No.

請參照 PAG.2 8、9 項

#### 壓力範圍 Pressure Range

SF	SFC	SM
AS: 10 kgf/cm <sup>2</sup>		
A: 20 kgf/cm <sup>2</sup>	A: 20 kgf/cm <sup>2</sup>	A: 35 kgf/cm <sup>2</sup>
B: 35 kgf/cm <sup>2</sup>	B: 35 kgf/cm <sup>2</sup>	B: 70 kgf/cm <sup>2</sup>
C: 55 kgf/cm <sup>2</sup>	C: 55 kgf/cm <sup>2</sup>	C: 105 kgf/cm <sup>2</sup> (僅有30L/min)
D: 70 kgf/cm <sup>2</sup>	D: 70 kgf/cm <sup>2</sup>	D: 140 kgf/cm <sup>2</sup> (Only 30L/min)

#### 泵排量 Displacement at 1800rpm

12L/min	20L/min	30L/min	40L/min
---------	---------	---------	---------

#### 系列號碼 Series .no.

SF	SFC	SM
低壓變量葉片泵	附止回型變量葉片泵	中壓變量葉片泵

#### 葉片泵系列 Variable displacement Vane Pump Series

 技術資料/ TECHNICAL DATA

型式 MODEL	泵排量(無負荷時) DELIVERY AT NO LOAD (L/min)		壓力調整範圍 PRESSURE ADJ RANGE (kgf/cm <sup>2</sup> )	容許回轉速 SHAFT SPEED RANGE (rpm)		最高壓力 MAX. PRESSURE (kgf/cm <sup>2</sup> )	重量 WEIGHT (kg)
	1800rpm	1500rpm		最高 MAX.	最低 MIN.		
SF-12AS	12	10	5-10	1800	800	10	5.0
SF-12A			10-20			20	5.0
SF-12B			15-35			35	5.0
SF-12C			30-55			55	5.0
SF-12D			50-70			70	5.0
SF-20AS	20	17	5-10	1800	800	10	5.0
SF-20A			10-20			20	5.0
SF-20B			15-35			35	5.0
SF-20C			30-55			55	5.0
SF-20D			50-70			70	5.0
SF-30AS	30	25	5-10	1800	800	10	9.0
SF-30A			10-20			20	9.0
SF-30B			15-35			35	9.0
SF-30C			30-55			55	9.0
SF-30D			50-70			70	9.0
SF-40AS	40	35	5-10	1800	800	10	9.0
SF-40A			10-20			20	9.0
SF-40B			15-35			35	9.0
SF-40C			30-55			55	9.0
SF-40D			50-70			70	9.0
SM-30A	30	25	15-35	1800	800	35	9.7
SM-30B			20-70			70	9.7
SM-30C			50-105			105	9.7
SM-30D			70-140			140	9.7
SM-40A	40	35	15-35	1800	800	35	9.7
SM-40B			20-70			70	9.7

 產品特性/FEATURE

- |  |   |
|--|---|
| <ol style="list-style-type: none"> <li>1. 高壓力、高效率、運轉平順。</li> <li>2. 低噪音、低振動，符合低噪音工作環境要求。</li> <li>3. 反應靈敏，動作精確度高。</li> <li>4. SM系列壓力補償型調整裝置，提供穩定的操作特性。</li> <li>5. 結構簡單，容易維護及操作。</li> <li>6. 使用壽命長。</li> <li>7. 體積小，節省空間，可直接連結馬達使用。</li> </ol> | <ol style="list-style-type: none"> <li>1. High efficiency, high-pressure, operation.</li> <li>2. Extremely low vibration and noise level.</li> <li>3. Instant and sharp cut-off characteristics.</li> <li>4. Sturdy structure for high efficiency and long service life.</li> <li>5. Easy adjustment in handling and maintenance.</li> <li>6. Very low noise when operating.</li> <li>7. Sturdy structure for high efficiency and long service life.</li> </ol> |
|--|---|

# Variable Displacement Vane Pump

變量葉片泵系列

VCM-SF/SM/SFC

## 外型尺寸 / MEASUREMENT

VCM - SF -  $\frac{12}{20}$  - ※ - 10 - ※

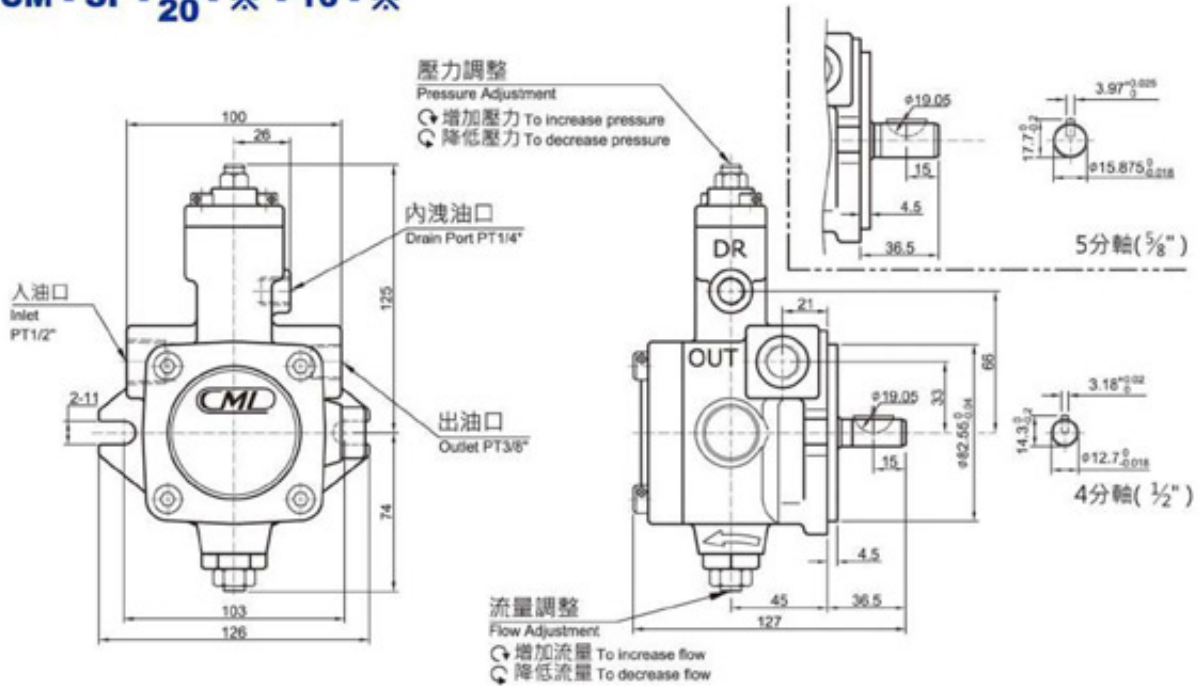

VCM - SF -  $\frac{12}{20}$  - ※ - 10 - ※

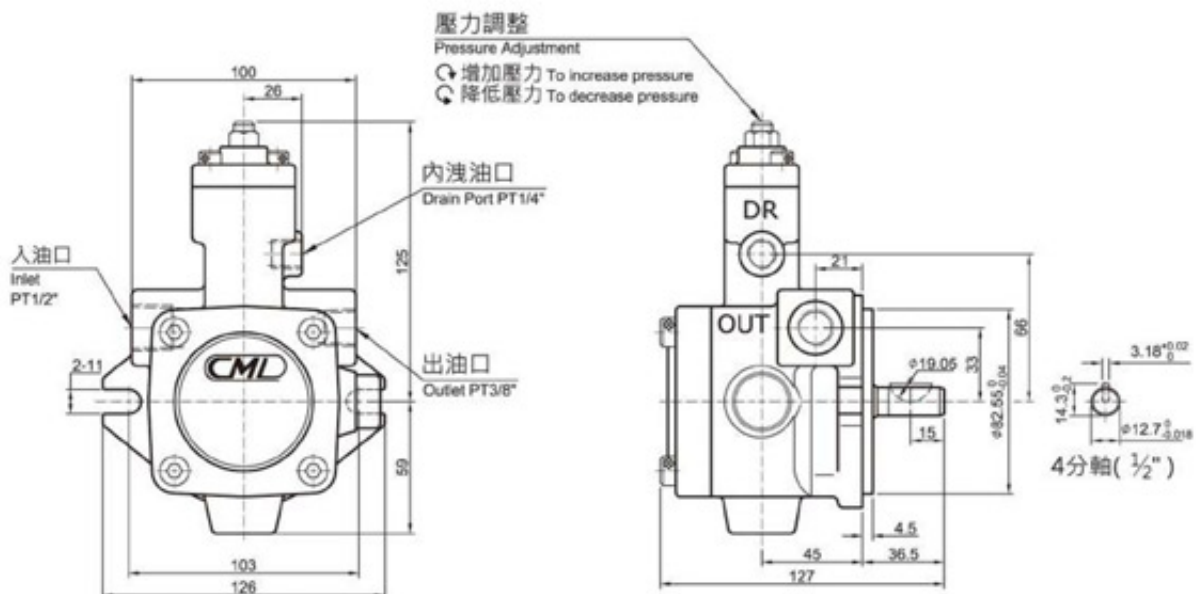

VCM - SF - 30 - ※ - 20 - ※

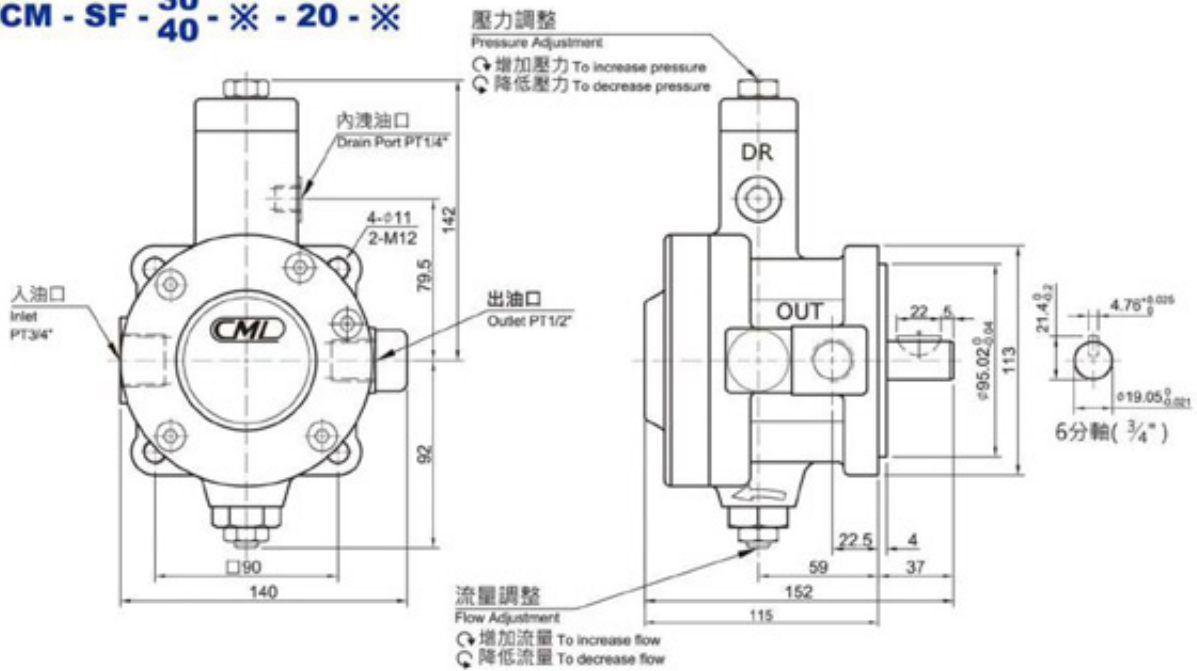

VCM - SF - 30 - ※ - 20 - ※

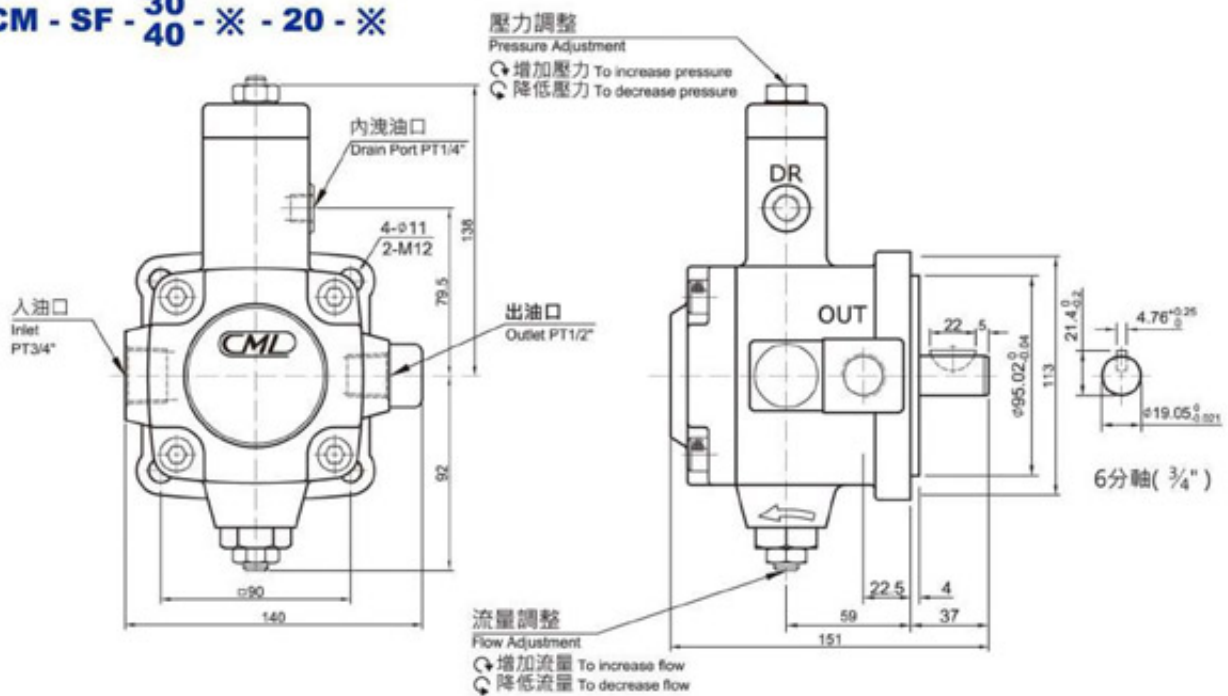

# Variable Displacement Vane Pump

變量葉片泵系列

## VCM-SF/SM/SFC

### 外型尺寸 / MEASUREMENT

#### VCM - SFC - 30 - 40 - ※

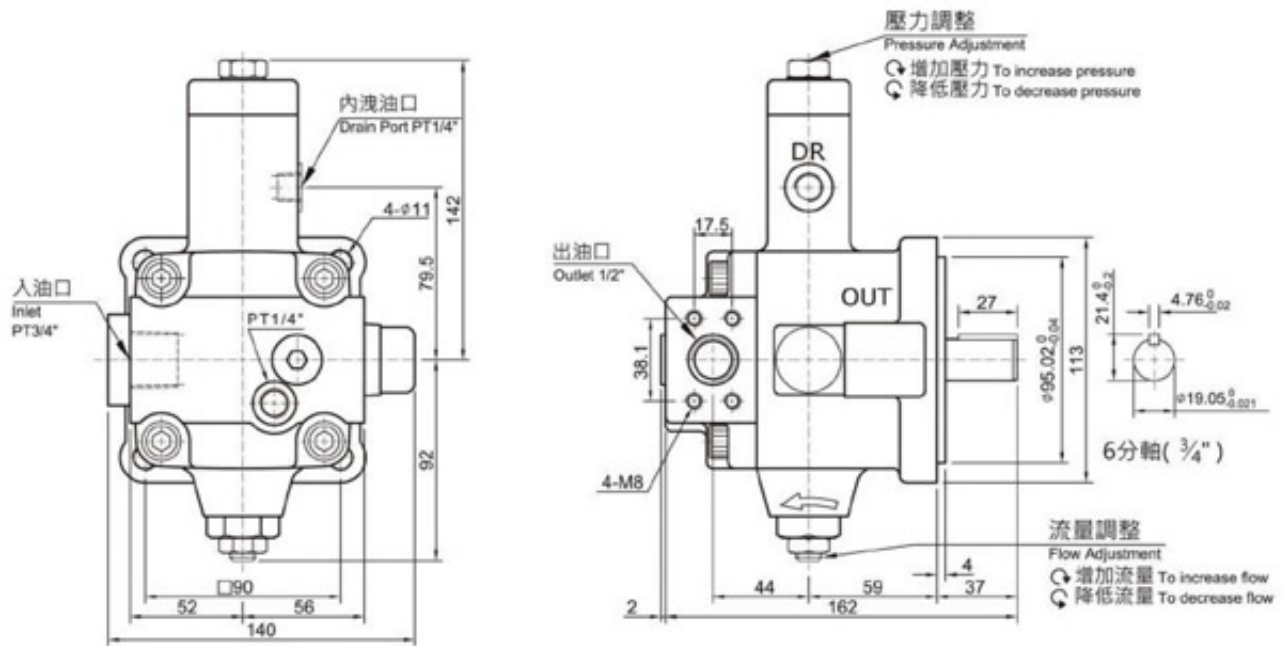

#### VCM - SM - 30 - 40 - ※

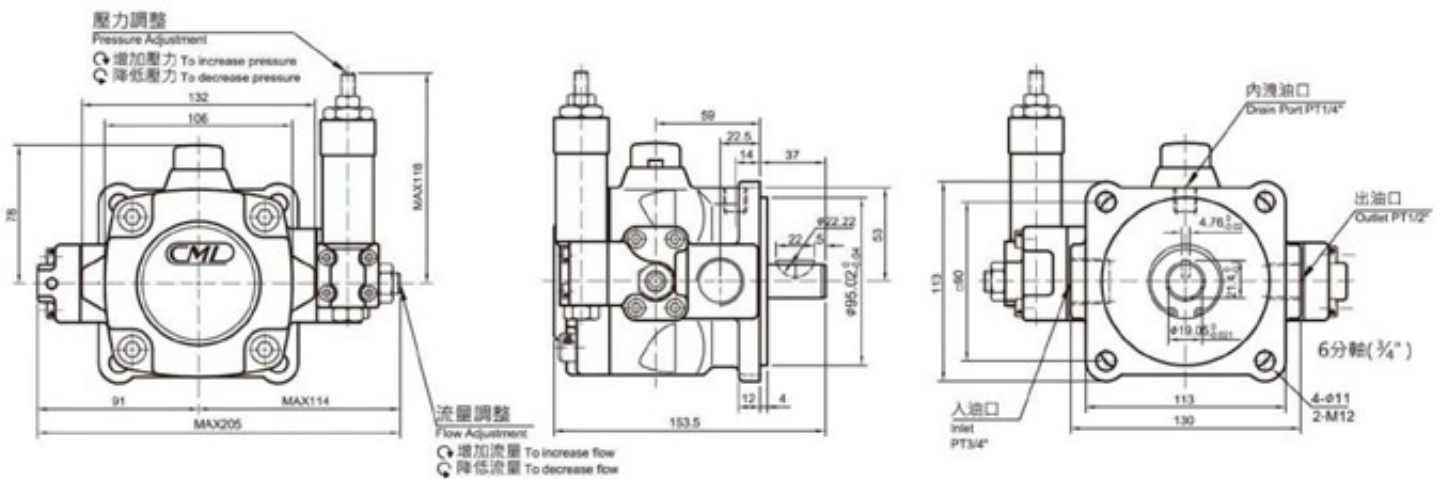

 性能曲線圖/PERFORMANCE CURVES

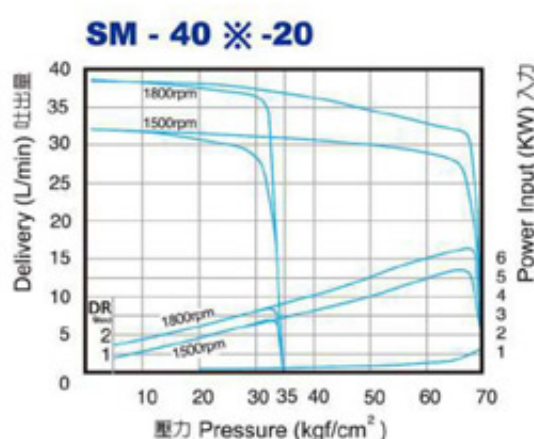
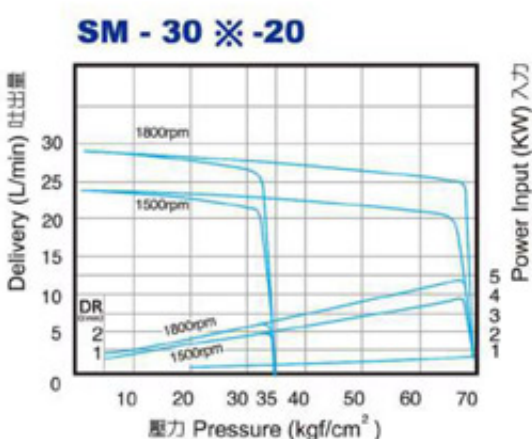
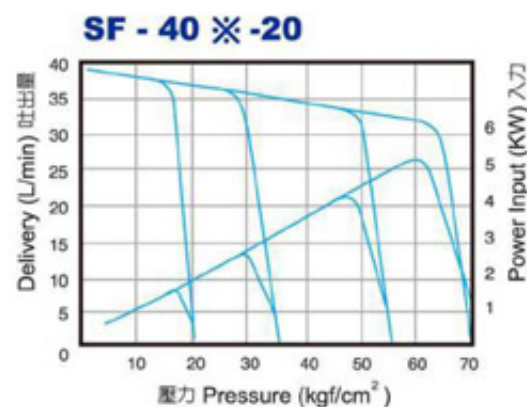
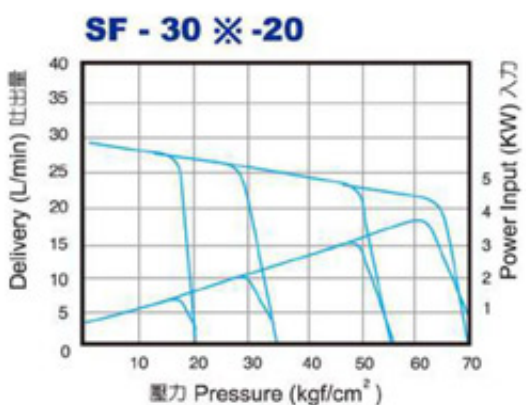
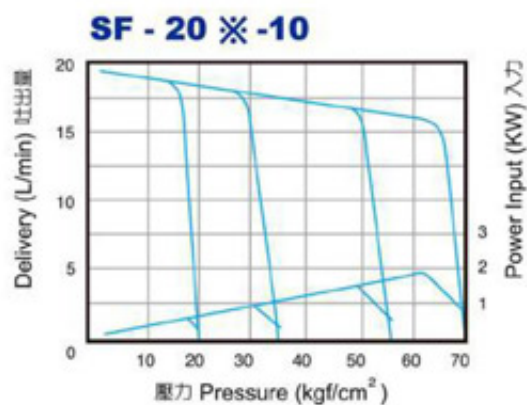
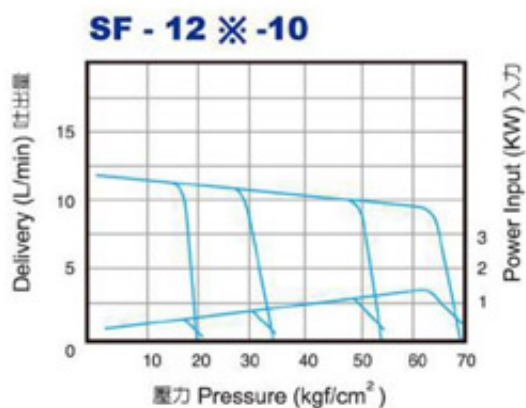

測試條件：液壓油溫度40°C±5°C，液壓油等級ISO VG 46。

Testing conditions: Oil temperature 40°C±5°C, hydraulic oil ISO VG 46.

# Minimization Hydraulic Power Unit

## 小型化油壓單元



### 型式號碼/MODEL CODE

SPU - 25L - 2 - SF30C + 4CG - 38

#### 電壓 Voltage

22 : 220V

38 : 380V

50/60HZ 均通用 Could Be Switched

#### 冷卻循環泵排量 Cooling circulation pump type

4CG 6CG

#### 壓力範圍 Pressure Range

AS : 10kgf/cm<sup>2</sup>

A : 20 kgf/cm<sup>2</sup>

B : 35 kgf/cm<sup>2</sup>

C : 55 kgf/cm<sup>2</sup>

D : 70 kgf/cm<sup>2</sup>

#### 泵排量 Displacement at 1800rpm

12L/min

20L/min

30L/min

40L/min

#### 馬達功率 Motor Power

1 : 0.75KW

2 : 1.5KW

3 : 2.2 KW

5 : 3.7 KW

#### 油箱容量 Tank Capacity

10L、15L、25L、30L

#### 小型化油壓單元 Minimization Hydraulic Power Unit

### 產品特性/CHARACTERISTIC

1. 搭配獨家循環泵，降低液壓油溫，增加加工精度。
2. 油溫可控制在室溫 +15 °C 以內。
3. 減少噪音，安裝簡便。
4. 最小油量只需10L，減少機台內安裝空間。
5. 動力油壓單元小型化，降低液壓油使用量。

1. Unique Cooling-Circulation pump can reduce oil temperature and maintain the machining accuracy.
2. Oil temperature is able to be controlled +15°C with ambient environment.
3. Noise reduced, Assembly easily
4. Min. oil capacity is 10 Liter, save space in the machines.
5. Compact power unit, hydraulic oil-saving 20-30%

## 傳統葉片泵與附冷卻葉片泵油溫性能比較圖/

### Oil temperature cooperation in between VCM-SF and VCM-SF/CG

- ▶ 與傳統變量葉片泵油溫相比，油溫較低於 7~10度(依環境溫度、操作、加工件、使用冷卻器規格等不同有所差異)。提供機台更穩定的油溫，使加工零件時能更穩定、更順暢、更精準控制。
- ▶ 測試條件：CNC車床進行實際零件加工，加工時間為八小時。

- ▶ Oil temperature of CG circulation pump will be reduced by 7-10°C (Depends on ambient temperature, operation conditions, machining materials, air-coolers, etc)
- ▶ Testing conditions: Real operation on CNC Lathe for 8 hours machining.

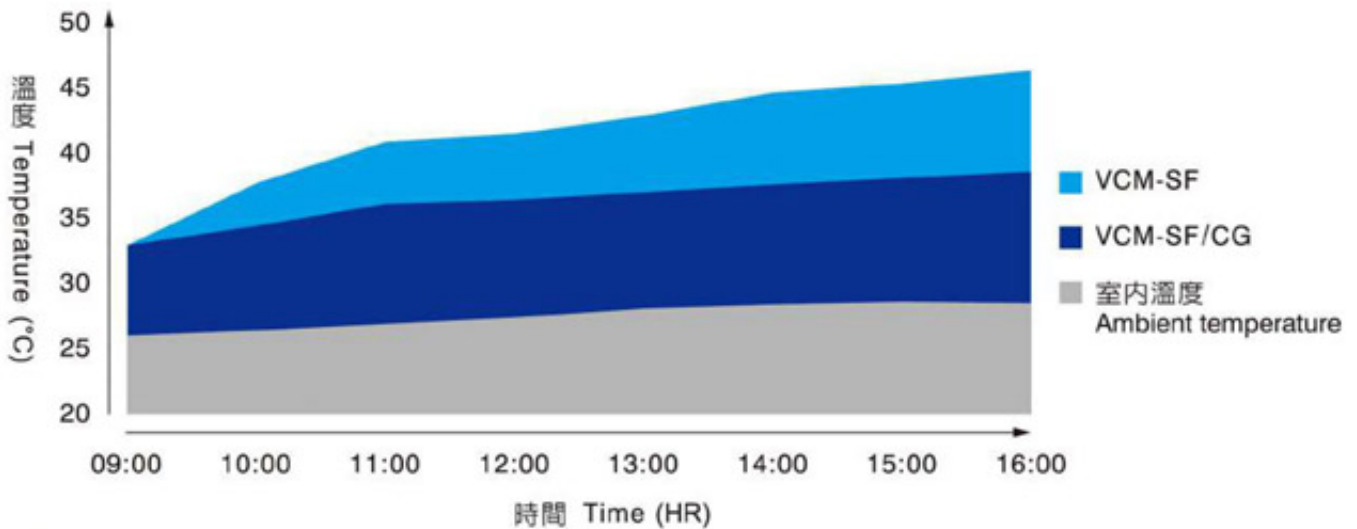

## 外型尺寸/ MEASUREMENT

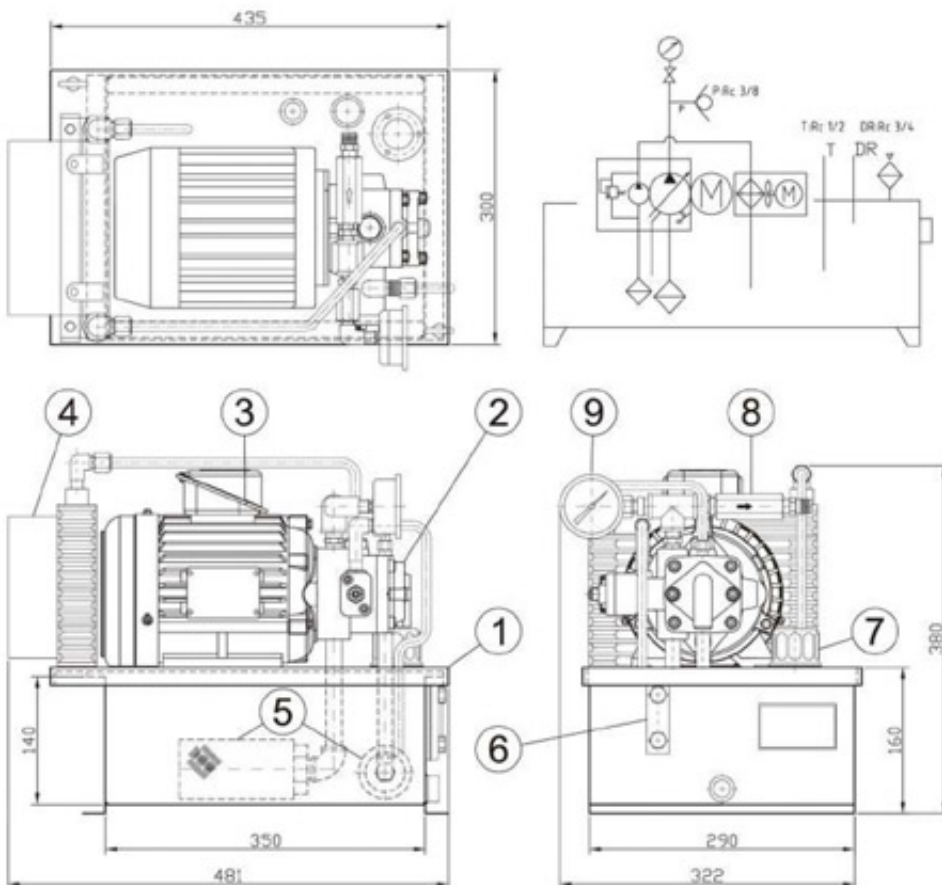

NO.	名稱 Model
1	油箱 Tank
2	循環泵浦 PUMP
3	馬達 Motor
4	油壓冷卻器 Heat Exchanger
5	濾油網 Filter
6	油面計 Oil level
7	注油器 Filler Breather
8	配管式止迴閥 Check Valve
9	壓力計 Pressure Gauge

若有不同規格、尺寸需求，請與本公司接洽。  
Different dimension requirements please contact with CAMEL company.



# Energy Saving Hydraulic Power Unit

## 節能變頻油壓單元



### 型式號碼/ MODEL CODE

HPU - 25L - 2 - SF30C + 4CG - 38

#### 電壓 Voltage

22 : 220V  
38 : 380V

#### 冷卻循環泵排量 Cooling circulation pump type

4CG、6CG

#### 壓力範圍 Pressure Range

B : 35 kgf/cm<sup>2</sup>  
C : 55 kgf/cm<sup>2</sup>  
D : 70 kgf/cm<sup>2</sup>

#### 泵排量 Displacement

30 : 30L/min  
40 : 40L/min

#### 馬達功率 Motor Power

2 : 1.5KW  
3 : 2.2 KW  
5 : 3.7 KW

#### 油箱容量 Tank Capacity

25L、35L

#### 變頻節能油壓單元 Energy Saving Hydraulic Power Unit

### 產品特性/ CHARACTERISTIC

1. 省電幅度達50-60%(持續保壓下)。
  2. 內藏式變頻器，節省安裝空間。
  3. 動力油壓單元小型化，降低液壓油使用量。
  4. 保壓時，可有效降低動力單元噪音，提高工作舒適性。
  5. 降低液壓油溫度，提高機械加工精度，延長零件使用壽命。
  6. 操作簡易，接通電源即可啓動動力單元
  7. 節能和傳統模式選擇，可簡易切換雙模式，不影響生產線運作
1. Power consumption saving 50-60% @ Holding Pressure
  2. Inverter can be assembled inside the tank, saving space in the machines.
  3. Compact power unit, hydraulic oil can be saved.
  4. Reducing noise during Holding Pressure, offering a comfortable working environment.
  5. Reducing oil temperature, improving accuracy of machining, extending working life time of hydraulic oil and components.
  6. Easy operation, start with normal plug.
  7. Exchable from Energy-saving to traditional mode during operation.

## 實機變頻節能曲線圖/ Energy Saving Graph

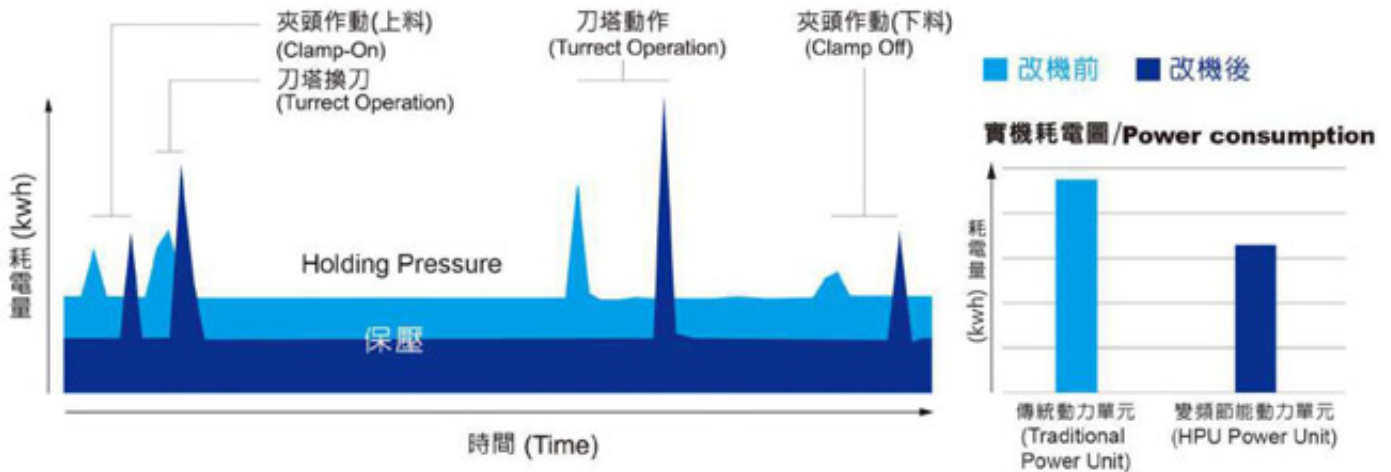

### 節能構造說明

- ▶ 省電30~60%(依加工工件、加工時間不同而有所差異)，保壓時間越久，效果更加明顯。
- ▶ 測試條件：台中精機小型車床實際加工一小時。其動作有換刀、夾持等動作，每工件加工時間約為115秒。一天工作16小時，連續365天工作，預計可以省下約800度電。
- ▶ Energy saved 30-60%. Depends on machining materials and time. The longer holding time, the more energy saved.
- ▶ Testing condition: Operation on Victor-Taichung CNC Lathe for 1 hour. Including turret switches, chucking, etc. Each working cycle 115s. If working time 16hr/day, 365days/year, total energy-saved 800(kWh) annually.

## 外型尺寸/ MEASUREMENT

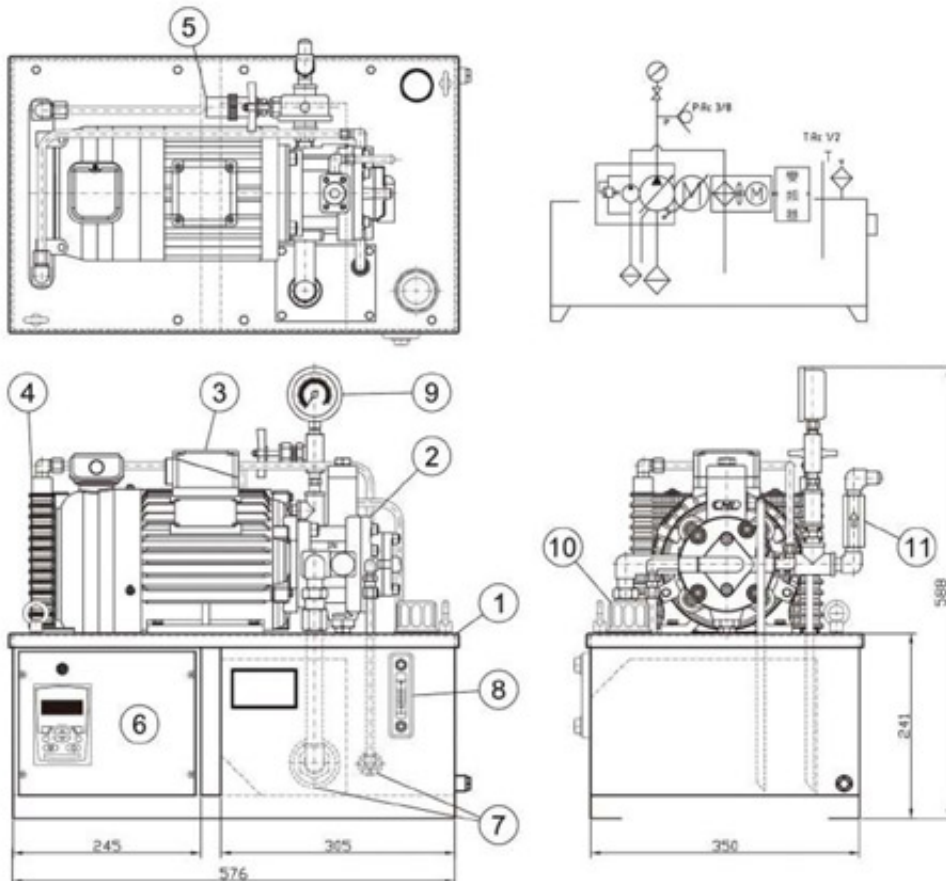

NO.	名稱 Model
1	油箱 Tank
2	循環泵浦 PUMP
3	馬達 Motor
4	油壓冷卻器 Heat Exchanger
5	壓力感測器 Pressure Transmitter
6	變頻器 Inverter
7	濾油網 Filter
8	油面計 Oil level
9	注油器 Filler Breather
10	配管式止逆閥 Check Valve
11	壓力計 Pressure Gauge

若有不同規格、尺寸需求，請與本公司接洽。  
Different dimension requirements please contact with CAMEL company.

# Notice

## 使用及注意事項

### 一、轉動方向

- ▶ 標準油泵的回轉方向乃以從軸心方向時正視為順時針方向。

### 二、液壓油

- ▶ 70kgf/cm<sup>2</sup>以下，40°C時，黏度為30-50cSt (ISO VG 32)的液壓油。
- ▶ 70kgf/cm<sup>2</sup>以上，40°C時，黏度為50-70cSt (ISO VG 46)的液壓油。

### 三、洩油管

- ▶ 洩油管請務必連接到油箱液面下，背壓請保持在0.3kgf/cm<sup>2</sup>以下。
- ▶ 回油管請插入油箱液面下，並盡量遠離吸油口管，或以隔板隔離。

### 四、工作油溫

- ▶ 連續運轉溫度約為15-60°C

### 五、軸心配差

- ▶ 油泵與馬達軸心偏心誤差須在0.05mm以下，角度誤差1°，在泵軸上不能有徑向力。
- ▶ 當軸心不一致時，會產生異音、震動、溫升，造成油泵故障原因。

### 六、流量調整

- ▶ 調整流量時須先放鬆螺帽，再旋轉調整螺絲，右轉時為減量，反之則為增量，調整完畢請務必鎖緊螺帽。

### 七、壓力調整

- ▶ 右轉壓力調整螺絲則輸出壓力升高，左轉則降低。

### 八、濾油器

- ▶ 液壓油的汙染，是油泵故障以及壽命降低的原因，請充分注意液壓油的汙染，控制污染度在NAS9級以內。

### 九、初次使用

- ▶ 請在無負載狀況下先行反覆啟動馬達，以排除管路及油泵中的空氣，為確保油泵系統當中所含空氣已排除，請讓油泵在無負載狀況下運轉10分鐘。

### 1. Direction of rotation

- ▶ The rotation of VCM-SF pump is clockwise when viewed from the shaft end.

### 2. Hydraulic oil

- ▶ Under 70 kgf/cm<sup>2</sup> the viscosity of oil must be within 30-50 cst at the temperature of 40°C.
- ▶ Over 70 kgf/cm<sup>2</sup> the viscosity of oil must be within 50-70 cst at the temperature of 40°C.

### 3. Drain piping

- ▶ The drain pipe is directly connected to the oil tank and the position must be below the level of oil.
- ▶ Let the oil return piping under the oil level of the tank , keep away from suction piping or make the divided plate.

### 4. Working oil temperature

- ▶ Continuous operating temperature is about 15-60°C.

### 5. Alignment and infollotion of pumps

- ▶ For proper alignment of pump and electric motor shaft, the eccentricity between them must be kept within 0.05mm and the eccentric angle error between them must be kept within 1°
- ▶ If centering between the driving shaft and pump shaft is incorrect, the bearing and oil seal may be domoged and noise and vibration moy occur, which cause trouble with the pump.

### 6. Flow adjusting

- ▶ Flow adjusting screw is turned clockwise to increase flow and counterclockwise to decrease flow.

### 7. Pressure adjusting

- ▶ Pressure adjusting screw is turned clockwise to increase pressure and Counterclockwise to decrease pressure.

### 8. Filter

- ▶ When first time operation, the pump should be at no-load state-on delivery side and be repeated on and off the electric motor a number of times to make sure the air have been bled out of the system.

### 9. Coughtions for starting

- ▶ Do not operate the pump of full speed right away, Instead, turn the motor input switch on-off severol times so as to extract dir from the piping, then operate it continuously, At the stort, be sure to reduce the pressure of operate it unloaded.