

Speciality

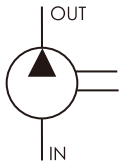

SCHEMATIC SYMBOL



SPECIFICATIONS

Model	Accurate Displacement Capacity (cc/rev)	Max. Pressure (kgf/cm ²)	Speed (r.p.m.)	
			Max.	Min.
HGP-2AK-F7(R/L) [KP10-7(C/A)]	7.26	175	3000	600
HGP-2AK-F9(R/L) [KP10-9(C/A)]	9.08	175	3000	600
HGP-2AK-F11(R/L) [KP10-11(C/A)]	11.2	175	3000	600
HGP-1.5A-F3.4L	3.4	-	3000	600

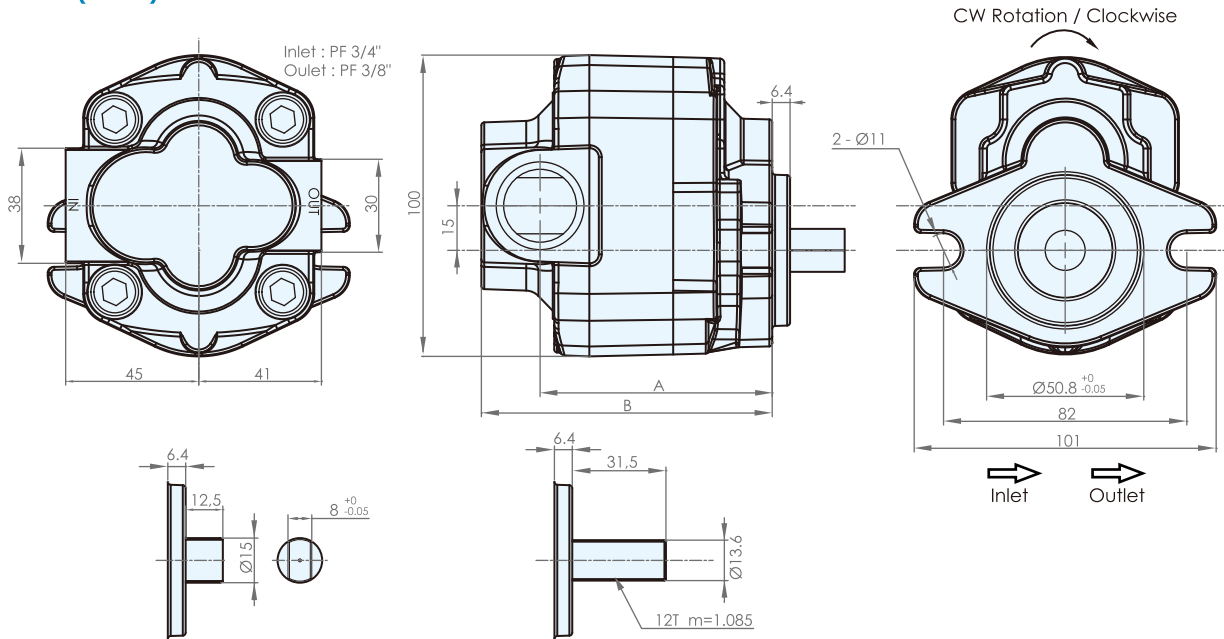
DIMENSIONS (unit : mm)
HGP-2AK (KP-10)

HGP-1.5A-F3.4L
