

# A10V28

Piston Type Main Pump For Excavator

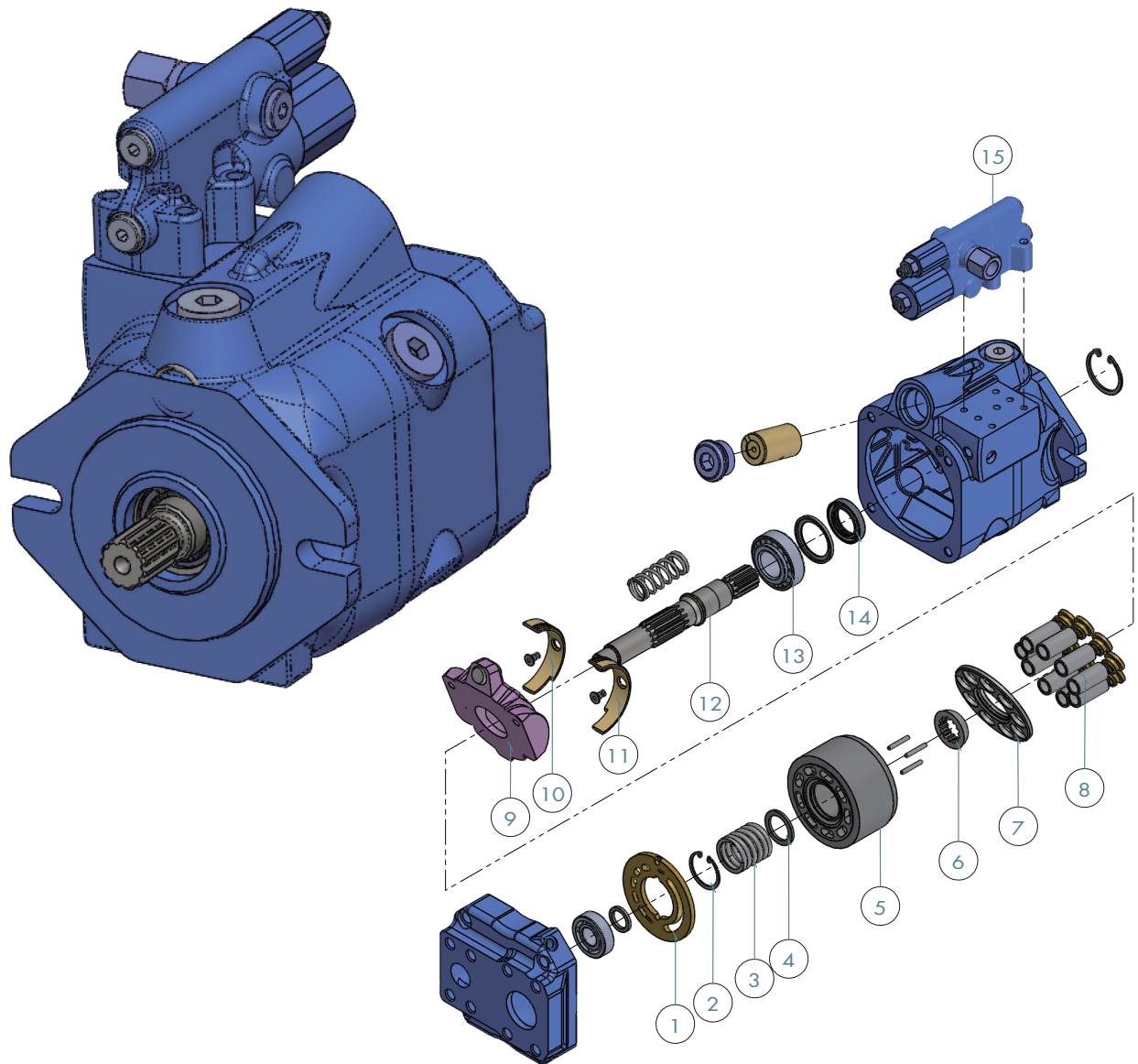

## PART NAME

NO.	Part Name
1	VALVE PLATE
2	STOP RING
3	SPRING. CYL'D BLOCK
4	SPING SEAT
5	CYLINDER BLOCK
6	BALL GUIDE
7	SET PLATE
8	PISTON ASS'Y
9	SWASH PLATE
10	SLIDING BEARING (L)
11	SLIDING BEARING (R)
12	SHAFT
13	BEARING
14	OIL SEAL
15	CONTROL VALVE

## SPECIFICATIONS

MODEL	Displacement	POWER	Max speed(rpm)	Flow	Torque	Weight
A10VNO28	28 cm <sup>3</sup>	42 HP	3200 RPM	90 l/min	94 NM	15 kg

## CHARACTERISTICS

- Cranes and lifting equipment
- Truck-mounted concrete pumps
- Cleaning vehicle

## CIRCUIT DIAGRAM

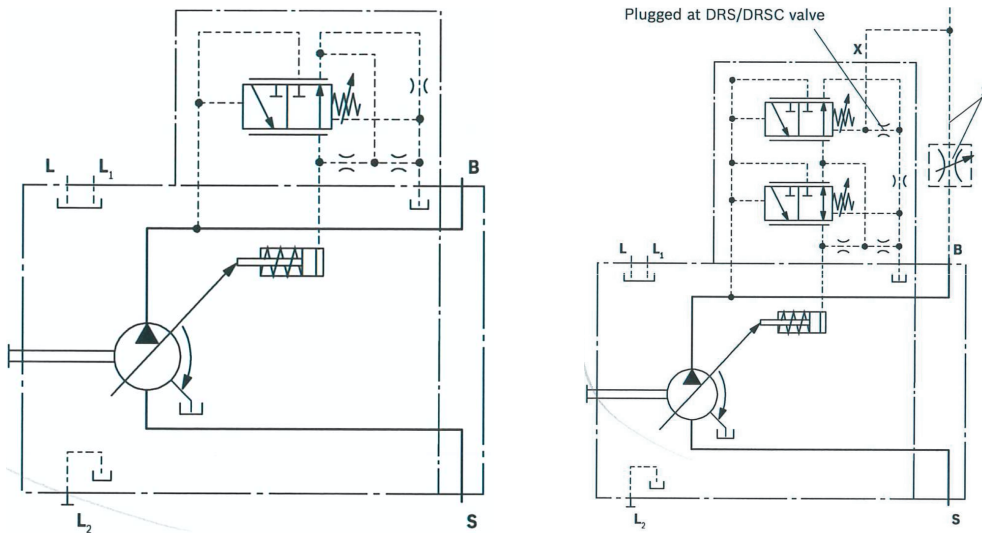

## DIMENSIONS

