

Gear Pump

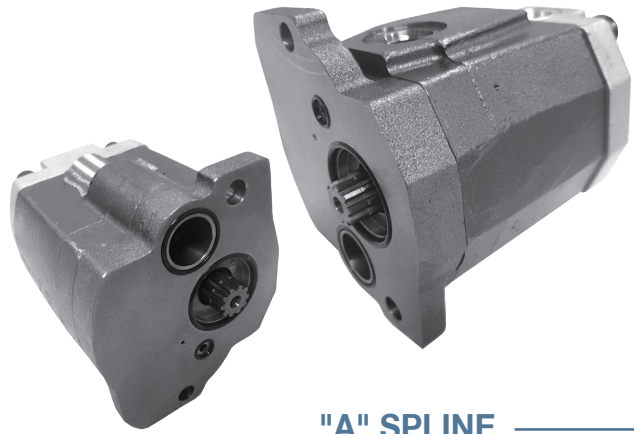
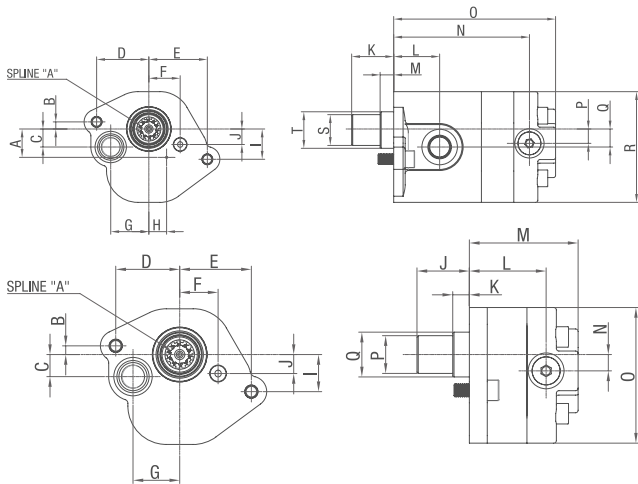

Model	A	B	C	D	E	F	G	H	I
KGPS (6.5cc)	26	7.8	16.25	50	56	30	36.5	17	28
	J	K	L	M	N	O	P	Q	
	40.95	13	60	85	13	106	35	30	

Model	A	B	C	D	E	F	G	H	I	J
KGPD (12.1+6.5, 16.2+4.5, 18.3+4.5)	26	7.8	16.25	50	56	30	36.5	17	28	18.66
	K	L	M	N	O	P	Q	R	S	T
	40.25	44	13	130	155	13	16	160	35	30

"A" SPLINE

Module	16/32
Pressure	30°
No. of teeth	13
Standard pitch circle diameter	Ø30.638

PTO

(K3V/K5V DTP Series)

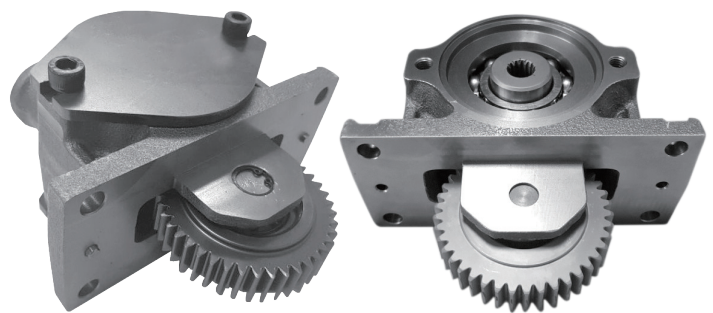
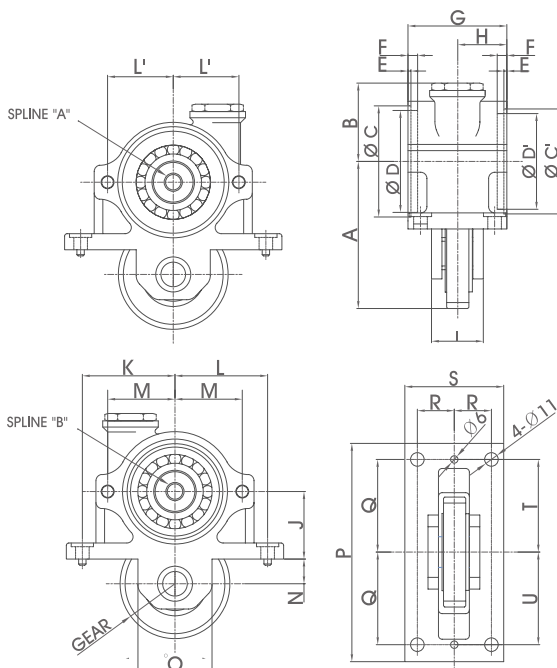

Model	A	B	C	D	C'	D'	E	F
PTO(A)	120	64	90	82.55	85	77.5	2.4	7.8
PTO(B)					90	82.5		
Model	G	H	I	J	K	L	M	N
PTO(A)	80	40	42	55	75	75	54.5	20
PTO(B)								
Model	O	P	Q	R	S	T	U	
PTO(A)	60	176	75	30	80	75	75	
PTO(B)								

	SPLINE "B"	SPLINE "A"	GRAR
Module	1	16/32	2
No. of teeth	13	10	42
Pressure	20°	30°	20°
Standard pitch circle diameter	Ø13	Ø15.875	Ø84

Sol. valve

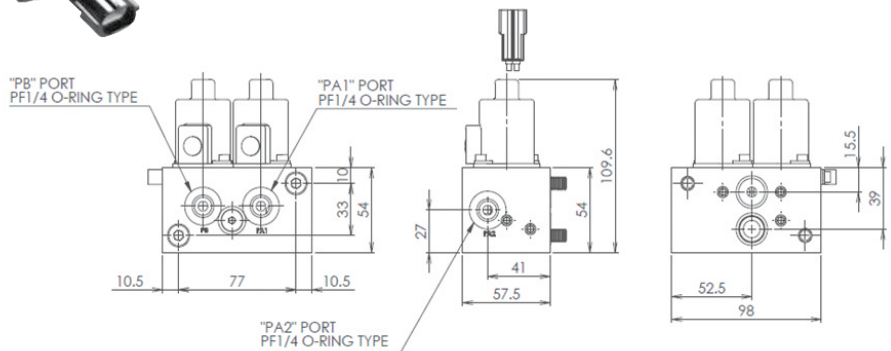
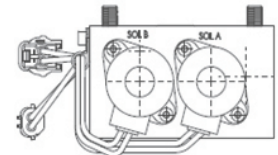
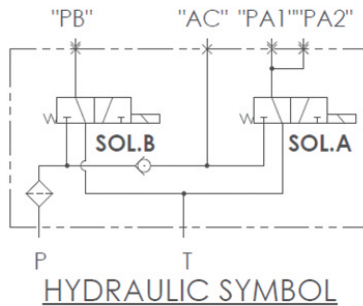
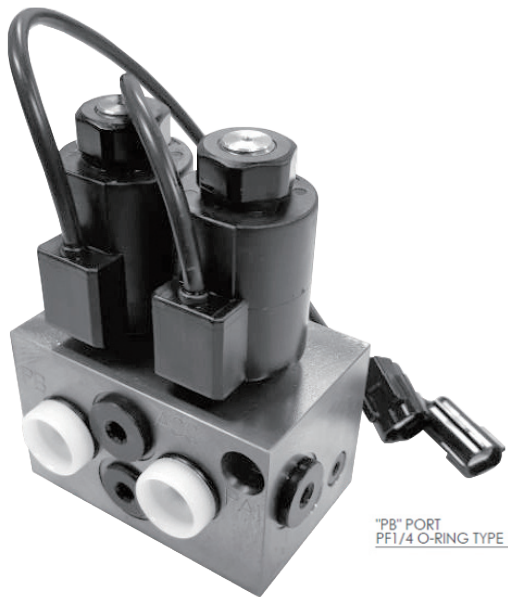

EPPR VALVE

5K 10/40, 9N2T 5K 10/40, DPA TYPE, 5K 20/40, 9N1T 5K 20/40



TDRDE 5K-10

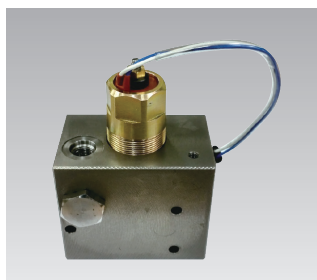

TDRDE 5K-20



DPA TYPE



TDRDE 5V-20



TDRDE 5K-10



TDRDE 5K-20



REG' EPPR V/V
5KR 20/40 / 5K 20/40

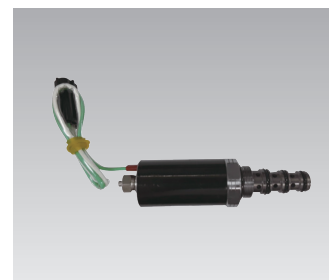

REG' EPPR
5KR 20/40 / 5K 20/40