

Throttle check valve

Type Z2FS

RE 27536

Edition: 2018-04

Replaces: 05.08



- ▶ Size 25
- ▶ Component series 3X
- ▶ Maximum operating pressure 350 bar
- ▶ Maximum flow 360 l/min

Features

- ▶ Sandwich plate valve
- ▶ Porting pattern according to ISO 4401-08-08-0-05
- ▶ For flow limitation of 2 actuator ports
- ▶ Adjustment type: Spindle with internal hexagon
- ▶ For supply or discharge throttling
- ▶ Corrosion-protected design

Contents

Features	1
Ordering code	2
Symbols	2
Function, section	3
Technical data	4
Characteristic curves	5
Dimensions	6
Further information	7

Ordering code

01	02	03	04	05	06	07	08	09
Z2FS	22		8	-	3X	/		*

01	Throttle check valve, sandwich plate design	Z2FS
02	Size 25	22
03	Throttle check valve side A and B	-
	Throttle check valve side A	A
	Throttle check valve side B	B

Adjustment type

04	Spindle with internal hexagon	8
05	Component series 30 ... 39 (30 ... 39: unchanged installation and connection dimensions)	3X
06	Supply throttling	S
	Discharge throttling	S2

Corrosion resistance (outside)

07	None (valve housing primed)	no code
	Improved corrosion protection (240 h salt spray test according to EN ISO 9227)	J3

Seal material

08	NBR seals	no code
	FKM seals	V
	Observe compatibility of seals with hydraulic fluid used. (Other seals upon request)	
09	Further details in the plain text	

Symbols (① = component side, ② = plate side)

Supply throttling "S"

Discharge throttling "S2"

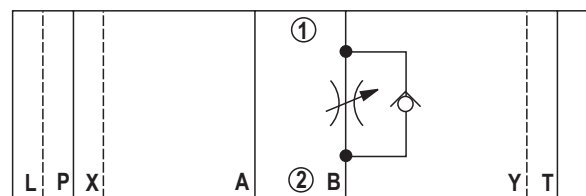
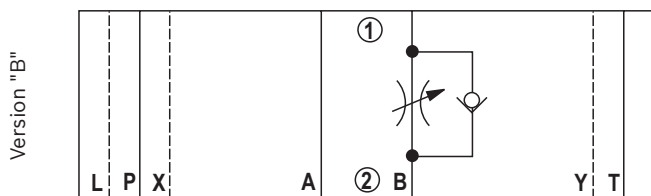
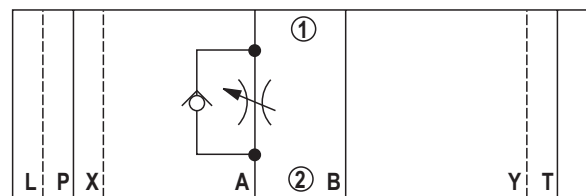
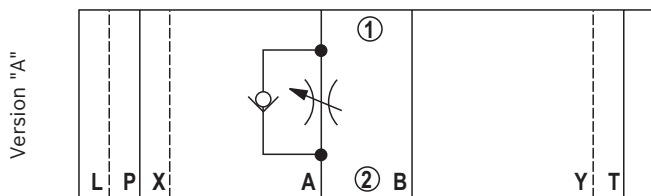
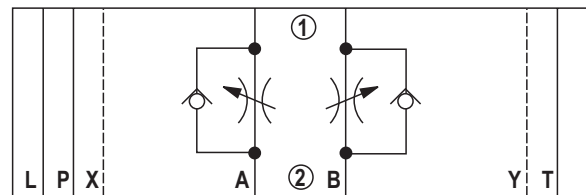
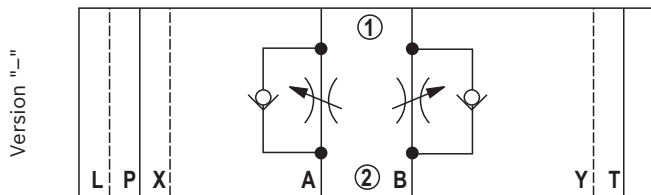

Function, section

The valve type Z2FS is a throttle check valve in sandwich plate design. It is used for the flow limitation of one or two actuator ports.

Two symmetrically arranged throttle check valves limit flows (by adjustable throttle spools) in one direction and allow free return flow in the opposite direction.

In case of supply throttling, the hydraulic fluid is directed through channel A① via throttling point (1) to actuator A②.

The throttle spool (2.1) can be axially adjusted via the spindle (3) for adjustment of the throttling point (1).

Simultaneously, the hydraulic fluid in channel A① is directed via the bore (4) to the piston side (5). The active pressure and the spring force retain the throttle spool (2.1) in throttle position.

The hydraulic fluid return flow from actuator B② displaces the throttle spool (2.2) and enables the unobstructed flow as check valve. Depending on the version ("S" or "S2"), the throttling effect may occur in supply or discharge.

Flow limitation

For actuator velocity adjustment, the throttle check valve is installed between the directional valve and the subplate.

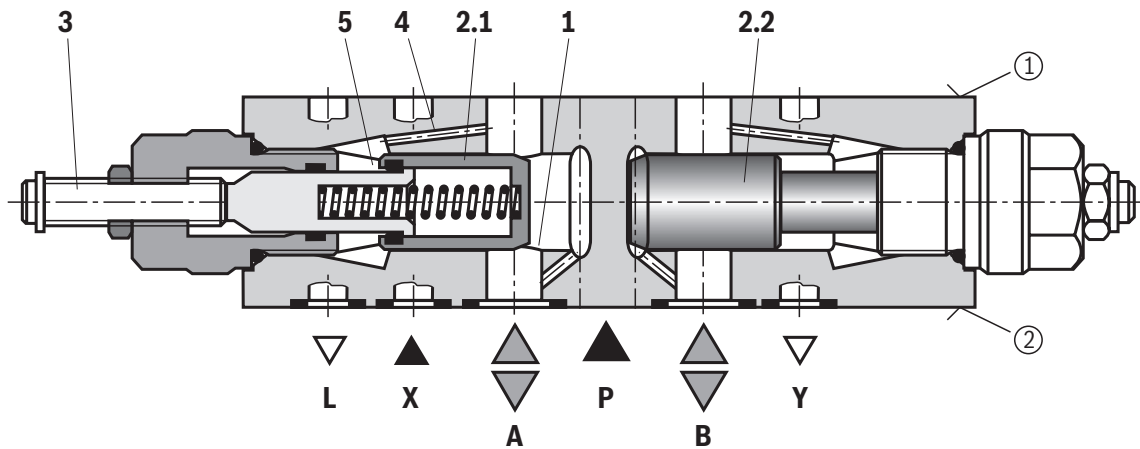

Supply throttling

① = component side
② = plate side

Technical data

(For applications outside these parameters, please consult us!)

general		
Weight	kg	8
Installation position		any
Ambient temperature range	°C	-30 ... +50 (NBR seals) -20 ... +50 (FKM seals)

hydraulic		
Maximum operating pressure	bar	350
Maximum flow	l/min	360
Hydraulic fluid		see table below
Hydraulic fluid temperature range	°C	-30 ... +80 (NBR seals) -20 ... +80 (FKM seals)
Viscosity range	mm ² /s	2.8 ... 380
Maximum admissible degree of contamination of the hydraulic fluid, cleanliness class according to ISO 4406 (c)		class 20/18/15 ¹⁾

Hydraulic fluid	Classification	Suitable sealing materials	Standards	Data sheet
Mineral oils	HL, HLP, HLPD, HVLP, HVLPD	NBR, FKM	DIN 51524	90220
Bio-degradable	▶ Insoluble in water	HETG ²⁾	ISO 15380	90221
		HEES ²⁾		
	▶ Soluble in water	HEPG ²⁾	ISO 15380	
Flame-resistant	▶ water-free	HFDU (glycol base)	ISO 12922	90222
		HFDU (ester base) ²⁾		
		HFDR		
	▶ containing water	HFC (Fuchs Hydrotherm 46M, Petrofer Ultra Safe 620) ²⁾	ISO 12922	90223



Important information on hydraulic fluids:

- ▶ For further information and data on the use of other hydraulic fluids, please refer to the data sheets above or contact us.
- ▶ There may be limitations regarding the technical valve data (temperature, pressure range, life cycle, maintenance intervals, etc.).
- ▶ The ignition temperature of the hydraulic fluid used must be 50 K higher than the maximum surface temperature.

▶ Flame-resistant – containing water:

- Maximum pressure differential 210 bar, otherwise, increased cavitation erosion
- Life cycle as compared to operation with mineral oil HL, HLP 30 ... 100%
- Maximum hydraulic fluid temperature 60 °C

- ▶ **Bio-degradable and flame-resistant:** If this hydraulic fluid is used, small amounts of dissolved zinc may get into the hydraulic system.

Characteristic curves

(measured with HLP46, $\vartheta_{oil} = 40 \pm 5 \text{ }^\circ\text{C}$)

Δp - q_v characteristic curves (via check valve, with closed throttle)

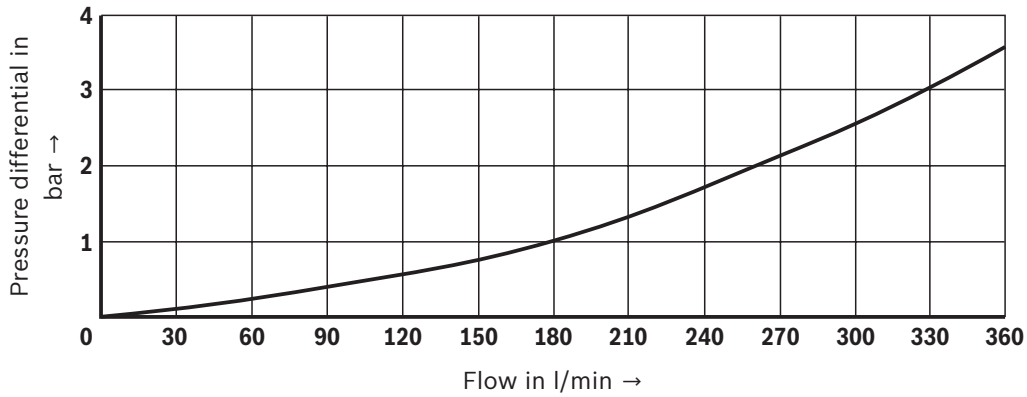

Δp - q_v characteristic curves (throttle position constant)

