

V series Piston Pump

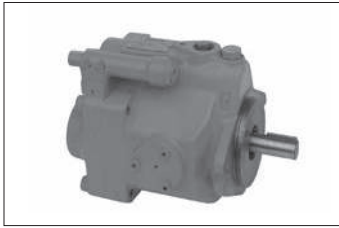

Features

- **Low noise**
 - Low noise operation over the entire pressure range has been realized in each series.
- **High efficiency**
 - Fluid temperature rise can be reduced due to the smaller power loss. This means that the tank can be designed in a small size.
- **High reliability**
 - High responsiveness, high stability, and long life make it possible to increase the reliability of the main machine.

Nomenclature

● Pressure compensator control

※ - V ※※ A ※ ※ ※ - ※※ ※※
 1 2 3 4 5 12 15 16 17

● Combination control (pressure feedback method)

※ - V ※※ C ※ ※ R H X - ※※ ※※
 1 2 3 4 7 8 12 13 15 16 17

● Combination control (solenoid operated method)

※ - V ※※ C ※ ※ R J ※ X - ※※ ※※
 1 2 3 4 7 8 12 13 14 15 16 17

● Dual pressure control

※ - V ※※ D ※ ※ R ※ X - ※※ ※※
 1 2 3 4 9 10 12 14 15 16 17

● Power-match control

※ - V ※※ SA ※ ※ ※ ※ - ※※
 1 2 3 4 6 11 12 15 16

1 Applicable fluid code (Refer to Page A-5 for the applicable models and conditions of use)

No designation: Petroleum-based hydraulic fluid
 W: Water-glycol hydraulic fluid
 F: Phosphate ester hydraulic fluid

2 Model No.

V: V series piston pump

3 Pump capacity

8: 8.0 cm³/rev
 15: 14.8 cm³/rev
 23: 23.0 cm³/rev
 38: 37.7 cm³/rev
 50: 51.6 cm³/rev
 70: 69.8 cm³/rev

4 Control method I (Refer to Page A-4 for the applicable models)

A: Pressure compensator control
 C: Combination control
 D: Dual pressure control
 SA: Power-match control

5 6 Pressure adjustment range (See the pressure adjustment range table)

7 9 Low pressure adjustment range (See the pressure adjustment range table)

8 10 High pressure adjustment range (See the pressure adjustment range table)

11 FC valve differential pressure

A: 0.7 MPa { 7 kgf/cm² }
 B: 1.4 MPa { 14 kgf/cm² }
 C: 2.1 MPa { 21 kgf/cm² }

12 Direction of rotation, when viewed from the shaft end (Refer to Page A-4 for the applicable models)

R: Clockwise (rightward)
 L: Counterclockwise (leftward)

*The direction of rotation (rightward or leftward) cannot be changed.

13 Control method II

H: Pressure feedback method
 J: Solenoid operated method

14 Voltage code for the solenoid valve

A: AC 100 V (50/60 Hz), AC 110 V (60 Hz)
 B: AC 200 V (50/60 Hz), AC 220 V (60 Hz)
 N: DC 12 V
 P: DC 24 V

15 Piping direction (Refer to Page A-4 for the applicable models)

No designation: Axial port
 X: Side port

16 Design No. (The design No. is subject to change) *1

20: Pump model V8, V50
 95: Pump model V15, V38
 30: Pump model V23
 <When control method I is A, CH, or SA>
 35: Pump model V23
 <When control method I is CJ or D>
 60: Pump model V70

Control method III

17 No designation: Without remote control system
 RC: With remote control system

Note:*1 Refer to Page A-68 for information on forward/backward compatibility.

Refer to Page N-2 for hydraulic unit piston packs incorporating V series piston pumps, Page N-17 for NDJ series new DAIPACKs, Page N-22 for ND series Mini-packs, Page N-27 for ND series new DAIPACKs, and Page N-30 for the NT series SSS MARK-II.

Models and pressure adjustment range table

● **Pressure compensator control (4 = A)**

5 Pressure adjustment range

Code	Pressure adjustment range MPa {kgf/cm ² }	Without remote control system						With remote control system				
		V8	V15	V23	V38	V50	V70	V15	V23	V38	V50	V70
1	0.8 to 7 { 8 to 70 }	✓	✓	✓	✓	-	-	-	-	-	-	-
1	1.5 to 7 {15 to 70 }	-	-	-	-	✓	✓	-	-	-	-	-
2	1.5 to 14 {15 to 140 }	-	✓	✓	✓	✓	✓	-	-	-	-	-
3	1.5 to 21 {15 to 210 }	-	-	-	-	-	-	✓	-	-	-	-
3	2 to 21 {20 to 210 }	-	-	-	-	-	-	-	-	✓	✓	-
3	3.5 to 21 {35 to 210 }	-	✓	✓	✓	✓	✓	-	-	-	-	-
4	1.5 to 25 {15 to 250 }	-	-	-	-	-	-	-	✓	✓	-	-
4	3.5 to 25 {35 to 250 }	-	-	✓	✓	-	-	-	-	-	-	-

● **Combination control [4 = C, 13 = H (self-regulation method) or 13 = J (solenoid operated method)]**

7 Low pressure adjustment range

Code	Pressure adjustment range MPa {kgf/cm ² }	Pressure feedback method				Solenoid operated method		
		V15	V23	V38	V70	V15	V23	V38
1	1.5 to 7 {15 to 70 }	-	-	-	✓	✓	✓	✓
1	2.5 to 7 {25 to 70 }	✓	✓	✓	-	-	-	-
2	1.5 to 14 {15 to 140 }	-	-	-	✓	✓	✓	✓
2	2.5 to 14 {25 to 140 }	✓	✓	✓	-	-	-	-

8 High pressure adjustment range

Code	Pressure adjustment range MPa {kgf/cm ² }	Without remote control system						With remote control system							
		Pressure feedback method				Solenoid operated method		Pressure feedback method				Solenoid operated method			
		V15	V23	V38	V70	V15	V23	V38	V15	V23	V38	V70	V15	V23	V38
1	1.5 to 7 {15 to 70 }	-	-	-	✓	✓	✓	✓	-	-	-	-	-	-	-
1	2.5 to 7 {25 to 70 }	✓	✓	✓	-	-	-	-	-	-	-	-	-	-	-
2	1.5 to 14 {15 to 140 }	-	-	-	✓	✓	✓	✓	-	-	-	-	-	-	-
2	2.5 to 14 {25 to 140 }	✓	✓	✓	-	-	-	-	-	-	-	-	-	-	-
3	2.0 to 21 {20 to 210 }	-	-	-	-	-	-	-	-	-	-	-	✓	-	-
3	2.5 to 21 {25 to 210 }	-	-	-	-	-	-	-	✓	-	-	✓	-	-	-
3	3.5 to 21 {35 to 210 }	✓	✓	✓	✓	✓	✓	✓	-	-	-	-	-	-	-
4	2.0 to 25 {20 to 250 }	-	-	-	-	-	-	-	-	-	-	-	-	✓	✓
4	2.5 to 25 {25 to 250 }	-	-	-	-	-	-	-	-	✓	✓	-	-	-	-
4	3.5 to 25 {35 to 250 }	-	✓	✓	-	-	✓	✓	-	-	-	-	-	-	-

● **Dual pressure control (4 = D)**

9 Low pressure adjustment range

Code	Pressure adjustment range MPa {kgf/cm ² }	V15	V23	V38
1	1.5 to 7 {15 to 70 }	✓	✓	✓
2	1.5 to 14 {15 to 140 }	✓	✓	✓

Note: If both low and high pressure adjustment ranges are the 1st pattern, the pressure adjustment range becomes 0.8 to 7 MPa {8 to 70 kgf/cm²}.

● **Power-match control (4 = SA)**

6 Pressure adjustment range

Code	Pressure adjustment range MPa {kgf/cm ² }	V15	V23	V38	V50	V70
1	0.8 to 7 { 8 to 70 }	✓	✓	✓	-	-
1	1.5 to 7 {15 to 70 }	-	-	-	✓	✓
2	1.5 to 14 {15 to 140 }	✓	✓	✓	✓	✓
3	3.5 to 21 {35 to 210 }	✓	✓	✓	✓	✓
4	3.5 to 25 {35 to 250 }	-	✓	✓	-	-

10 High pressure adjustment range

Code	Pressure adjustment range MPa {kgf/cm ² }	Without remote control system			With remote control system		
		V15	V23	V38	V15	V23	V38
1	1.5 to 7 {15 to 70 }	✓	✓	✓	-	-	-
2	1.5 to 14 {15 to 140 }	✓	✓	✓	-	-	-
3	2.5 to 21 {25 to 210 }	-	-	-	✓	-	-
3	3.5 to 21 {35 to 210 }	✓	✓	✓	-	-	-
4	2.5 to 25 {25 to 250 }	-	-	-	-	✓	✓
4	3.5 to 25 {35 to 250 }	-	✓	✓	-	-	-

Contact Details

Before using the product, please check the guide pages at the front of this catalog.

Internet

<http://www.daikinpmc.com/en/>

For latest information, PDF catalogs and operation manuals

Nomenclature

※ - V ※※ SAJS - ※ ※ X - ※※

1 2 3 4 5 6 7 8

1 Applicable fluid code

No designation: Petroleum-based hydraulic fluid
W: Water-glycol hydraulic fluid

2 Model No.

V: V series piston pump

3 Pump capacity

23: 23.0 cm³/rev
38: 37.7 cm³/rev
50: 51.6 cm³/rev
70: 69.8 cm³/rev

4 Control method

SAJS: Power-match control

5 Pressure adjustment range

A: Up to 14 MPa {140 kgf/cm²}
B: Up to 17.5 MPa {175 kgf/cm²}
C: Up to 21 MPa {210 kgf/cm²}

* The minimum adjustment pressure varies depending on the model.

6 Direction of rotation, when viewed from the shaft end (Refer to Page A-4 for the applicable models)

R: Clockwise (rightward)
L: Counterclockwise (leftward)

7 Piping direction

X: Side port

8 Design number (The design number is subject to change)

30: Pump model V23
95: Pump model V38
20: Pump model V50
60: Pump model V70

※ - V 15 A 1 R Y - 95

1 2 3 4 5 6 7 8

1 Applicable fluid code

No designation: Petroleum-based hydraulic fluid
W: Water-glycol hydraulic fluid
F: Phosphate ester hydraulic fluid

2 Model No.

V: V series piston pump

3 Pump capacity

15: 14.8 cm³/rev

4 Control method

A: Pressure compensator control

5 Pressure adjustment range

1: 0.8 to 7 MPa {8 to 70 kgf/cm²}

6 Direction of rotation, when viewed from the shaft end

R: Clockwise (rightward)

Piping port

Y: Suction port: Flange
Discharge port: Taper pipe threads

8 Design No. (The design No. is subject to change) *1

Note: *1 Refer to Page A-69 for information on forward/backward compatibility.

Specifications

Model No.	Theoretical discharge rate cm ³ /rev	Maximum operating pressure MPa {kgf/cm ² }	Permissible rotational speed min ⁻¹	Discharge rate adjustment range 1800 min ⁻¹ L/min		Mass (Control method A) kg	
				Axial port	Side port	Axial port	Side port
V8	8.0	7 {70}	500 to 1800	2 to 14.4		-	8.9
V15	14.8	21 {210}	500 to 1800	4.5 to 26.6	7.5 to 26.6	12.8	14.5
V15 (Type Y)	14.8	7 {70}	500 to 1800	4.5 to 26.6		13.5	
V23	23.0	25 {250}	500 to 1800	12 to 41.4		18.4	21.5
V38	37.7	25 {250}	500 to 1800	34 to 68	36.5 to 68	24.4	26
V50	51.6	21 {210}	500 to 1800	0 to 93		-	50
V70	69.8	21 {210}	500 to 1800	13 to 126		-	55

Note: JR-G (T) 02 and JRP-G02 are recommended for the remote control system's relief valve.

If the vent port is blocked, the pressure compensation structure does not work and the pump operates at a fixed pressure.

- Foot supports and piping flanges are not provided with the pump. Order them separately as required by referring to Pages S-2 and S-4.

Relationship between number of revolutions of the pressure adjusting screw and variation of discharge pressure

- The discharge pressure can be set to the desired value by turning the pressure adjusting screw of the PC valve.
 - Turning the adjusting screw clockwise increases the pressure.
 - Turning the adjusting screw counterclockwise decreases the pressure.

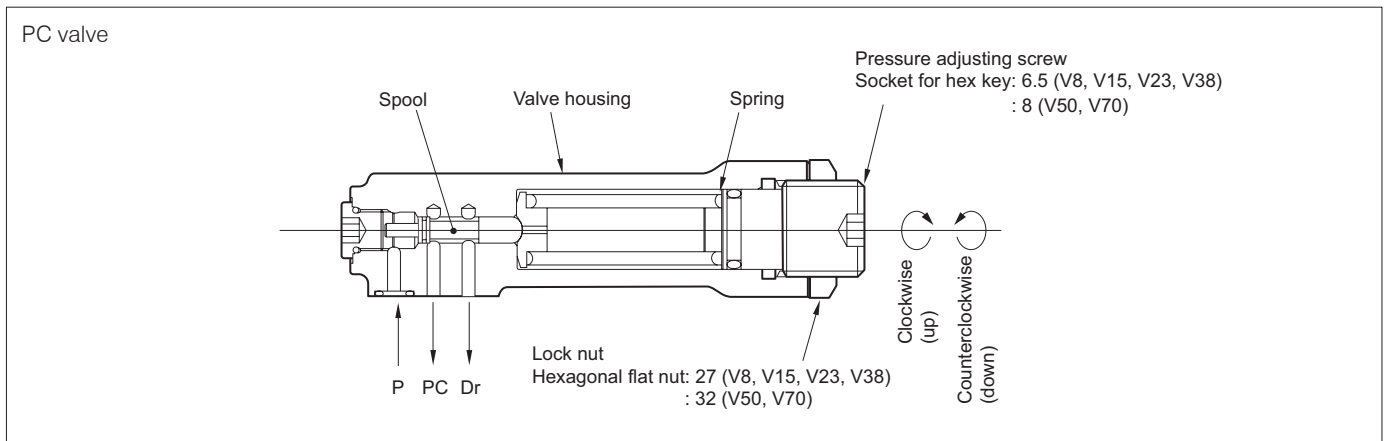
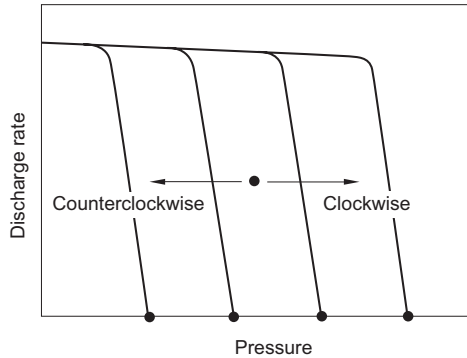

V8

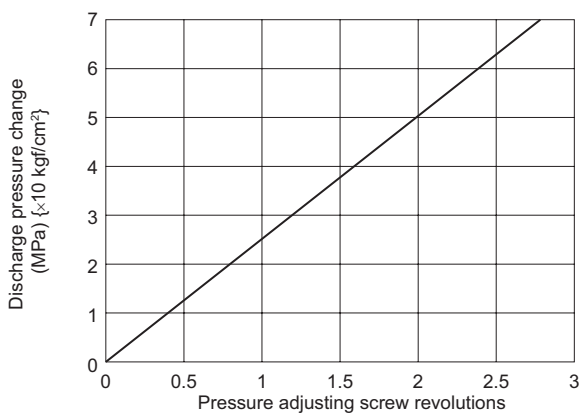

V15, 23, 38

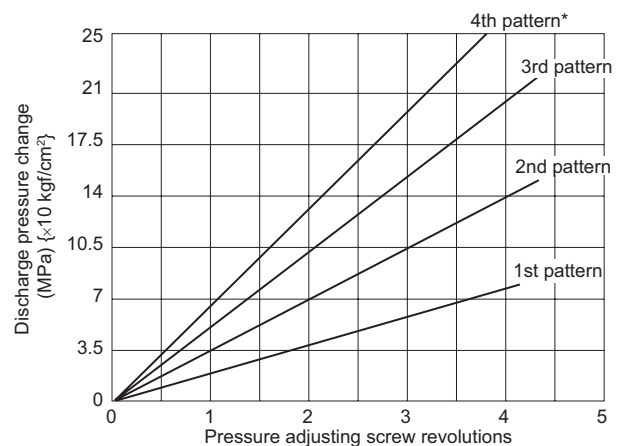

V50, 70

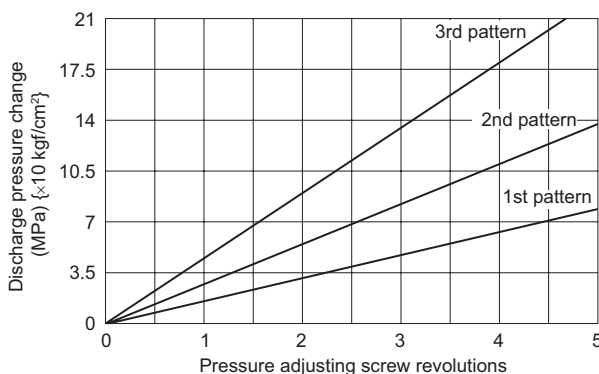

* The 4th pattern applies to V23 and V38.

- Excessive loosening of the pressure adjusting screw may cause oil to leak from the threaded section or parts to spring out. Do not loosen the screw beyond the pressure adjustment range.
- The 1st to 4th patterns correspond to the pressure adjustment range designation codes 1 to 4.

Relationship between the protruding length of the discharge rate adjusting screw and the discharge rate (4 = A, D, SA)

- The maximum discharge rate can be set to the desired value by turning the discharge rate adjusting screw at the end cap.
 - Turning the adjusting screw clockwise decreases the discharge rate.
 - Turning the adjusting screw counterclockwise increases the discharge rate.

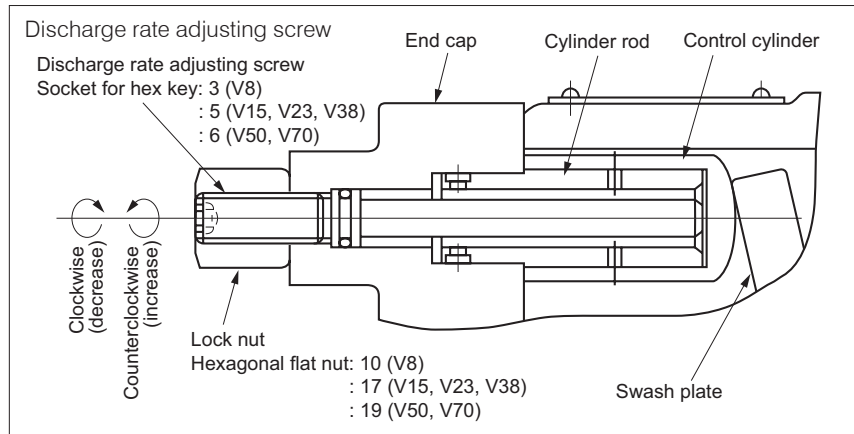
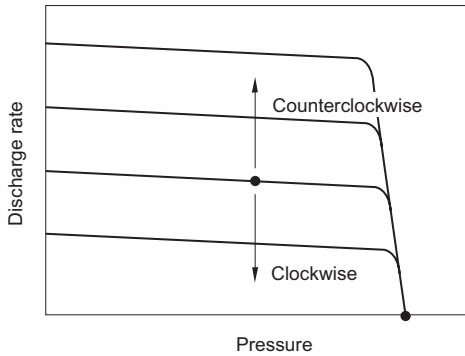

- The discharge rate can be roughly judged from the protruding length of the discharge rate adjusting screw (L).

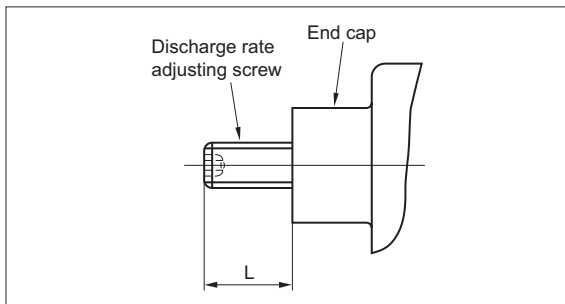

- Overtightening of the discharge rate adjusting screw may cause oil to leak from the threaded section. Do not tighten the screw beyond the adjustment range.

Contact Details

Before using the product, please check the guide pages at the front of this catalog.

Internet

<http://www.daikinpmc.com/en/>

For latest information, PDF catalogs and operation manuals

V8 side port

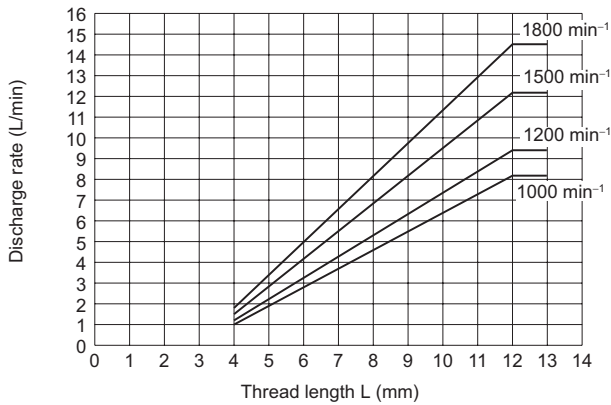

V15 axial port, V15 (type Y)

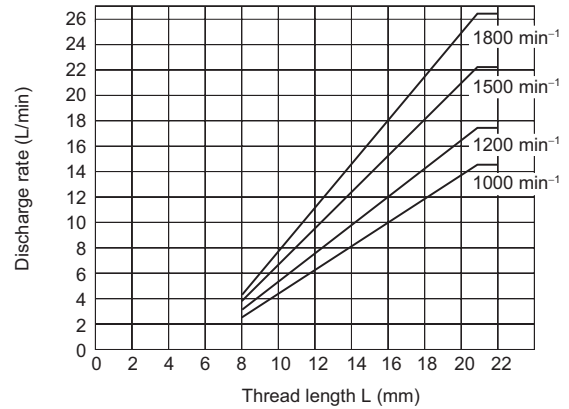

V15 side port

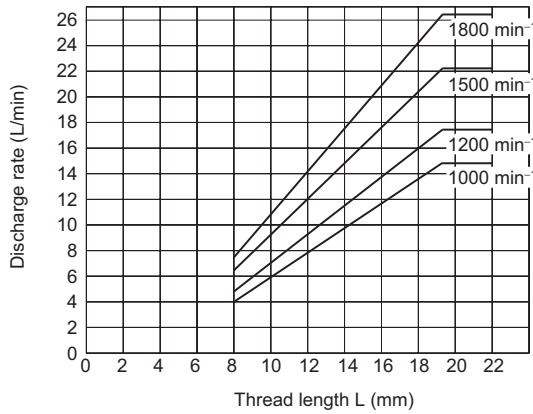

V23 axial port, side port

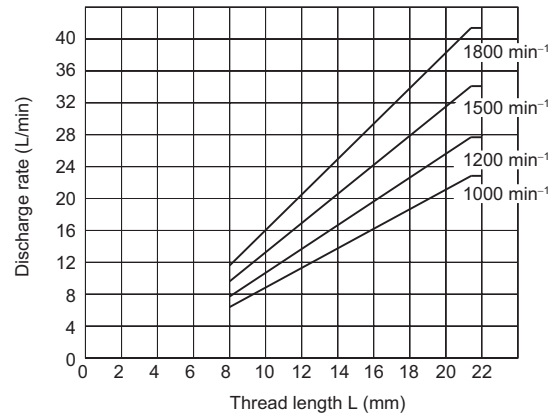

V38 axial port

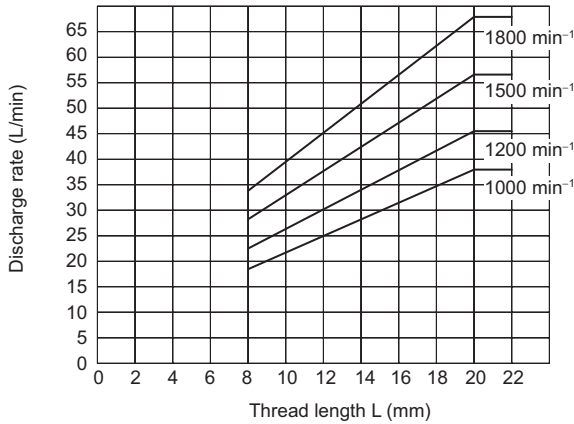

V38 side port

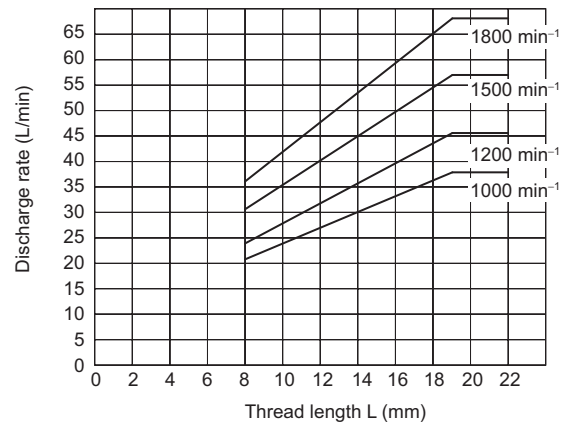

V50 side port

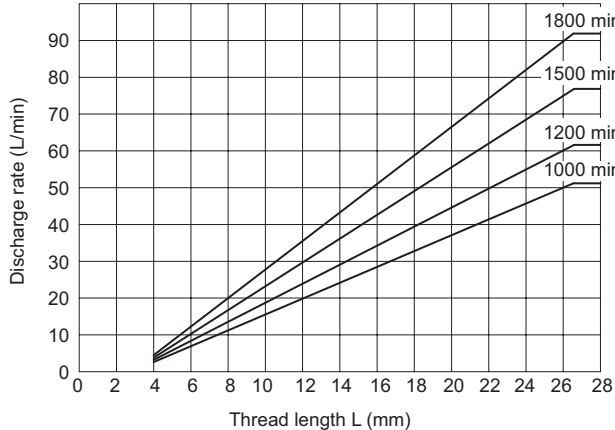

V70 side port

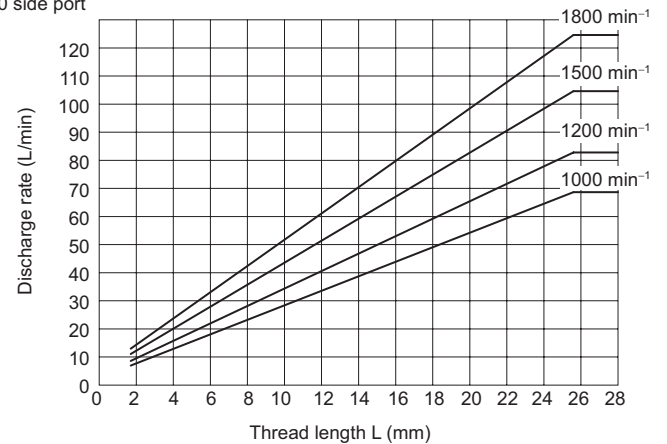

Relationship between the protruding length of the discharge rate adjusting screw and the discharge rate ($4 = C$)

● Discharge rate adjustment in combination control

The discharge rate for both the low quantity (QL) and high quantity (QH) ranges can be adjusted as follows:

- Turning the adjusting screw clockwise decreases the discharge rate.
- Turning the adjusting screw counterclockwise increases the discharge rate.

The discharge rate adjusting screws are provided with scales on the nameplates as shown below.

Pump model	Scale °	
	Low quantity adjusting screw	High quantity adjusting screw
V15C	0 to 7	5 to 15
V23C	0 to 9	8 to 17
V38C	0 to 9	9 to 18
V70C	0 to 9	6 to 18

(Scale graduation: 1°)

Note: The high quantity adjustment range may be restricted due to the setting for the low quantity range. See the graphs on Page A-15 for details.

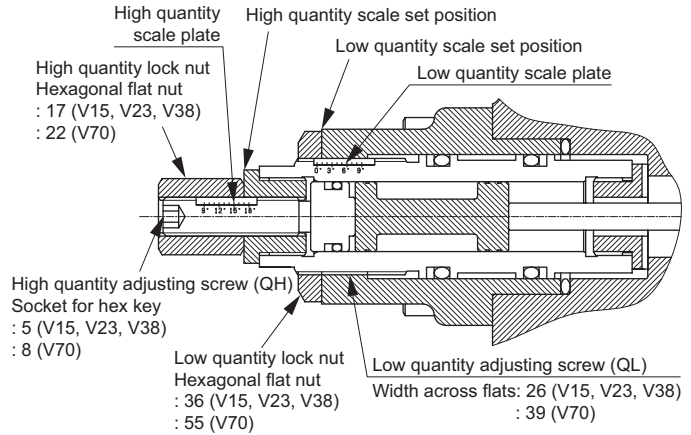

Adjust the discharge rate according to the relevant discharge rate adjustment graph by following the procedure below.

- (1) For the low quantity range, read the value for the desired discharge rate on the graph and turn the low quantity adjusting screw to set the scale position to the read value.
- (2) For the high quantity range, read the value for the desired discharge rate on the line corresponding to the value for the low quantity range on the graph and turn the high quantity adjusting screw to set the scale position to the read value.
- (3) When adjusting only the high quantity range, loosen the lock nut and adjust as described above.
- (4) When adjusting only the low quantity range, loosen the lock nut on the high quantity adjustment screw and adjust the setting for the low quantity range as described above while holding the high quantity adjusting screw in place with a hex key.

■ Example of adjustment

Example: When adjusting the discharge rate of V15C at 1500 min⁻¹ to 7 L/min for the low quantity range (QL) and 18 L/min for the high quantity range (QH)

- From the discharge rate adjustment graph for V15C at 1500 min⁻¹, first read the value for QL = 7 L/min, which is 4, and adjust the low quantity adjusting screw accordingly.
- Then, read the value for QH = 18 L/min on the line for 4 of QL, which is 7, and adjust the high quantity adjusting screw accordingly.

The setting values indicated above may change slightly depending on the conditions of use (fluid temperature, hydraulic fluid type, etc.)

For final fine adjustment, repeat the adjustment described above and achieve the setting appropriate for the actual application.

Factory settings

The discharge rate for the high quantity range is factory adjusted to the maximum discharge rate and the discharge rate for the low quantity range is generally factory adjusted as follows.

Pump model	Low quantity (QL) setting
V15C	Scale position: 6°
V23C	Scale position: 8°
V38C	Scale position: 7°
V70C	Scale position: 7°

Discharge rate adjustment graph for V15C in combination control

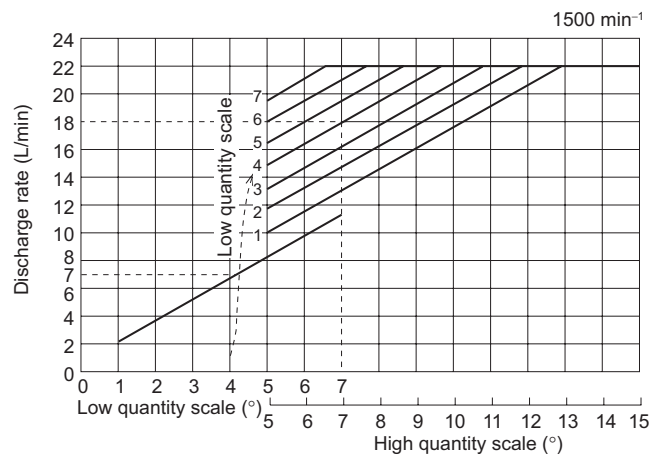

Contact Details

Before using the product, please check the guide pages at the front of this catalog.

Internet

<http://www.daikinpmc.com/en/>

For latest information, PDF catalogs and operation manuals

V15C combination control (1800 min⁻¹)

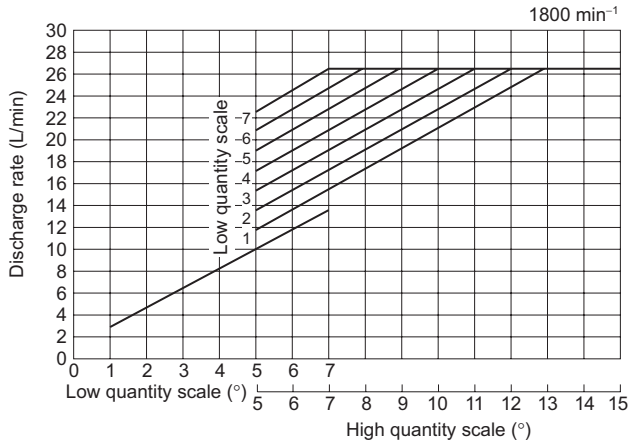

V15C combination control (1500 min⁻¹)

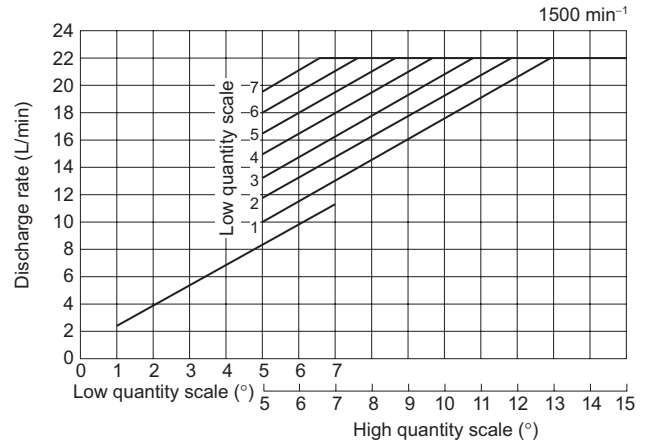

V23C combination control (1800 min⁻¹)

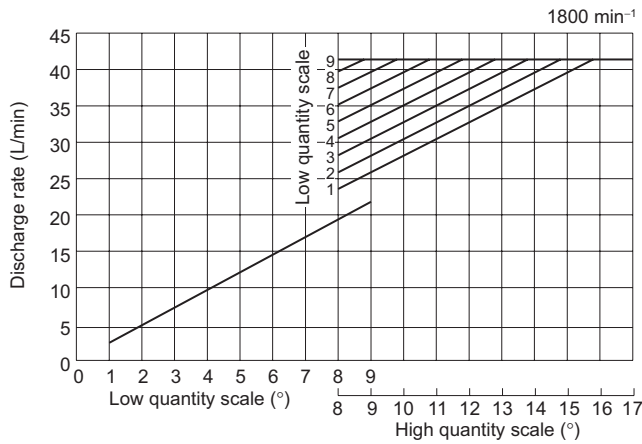

V23C combination control (1500 min⁻¹)

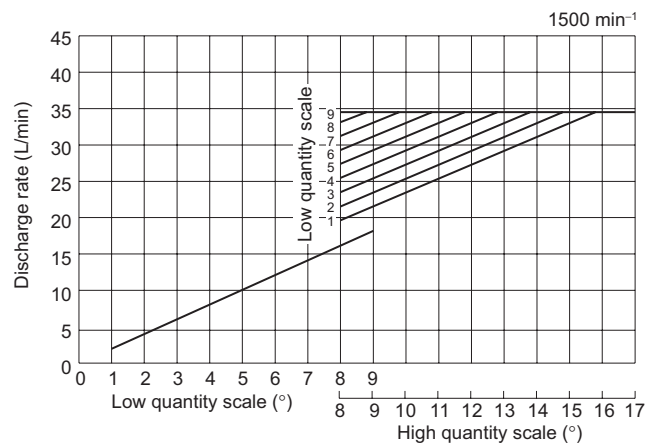

V38C combination control (1800 min⁻¹)

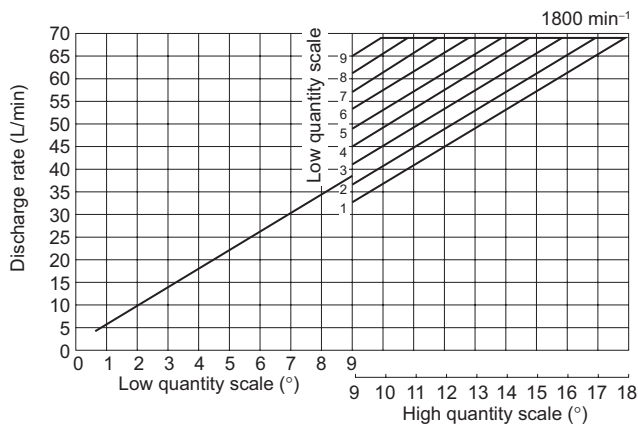

V38C combination control (1500 min⁻¹)

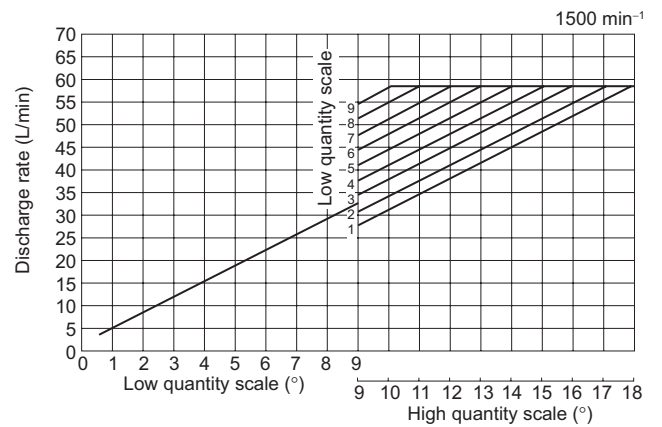

V70C combination control (1800 min⁻¹)

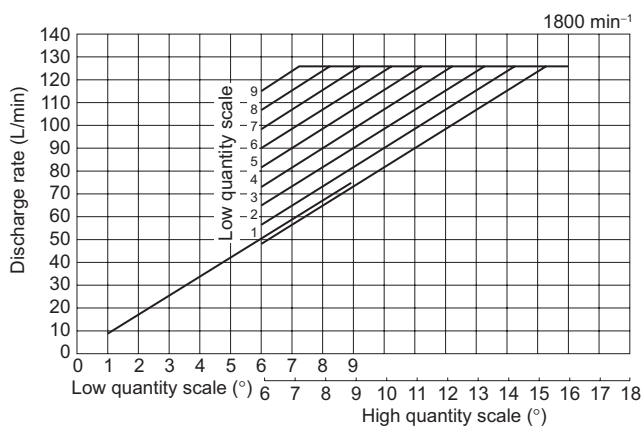

V70C combination control (1500 min⁻¹)

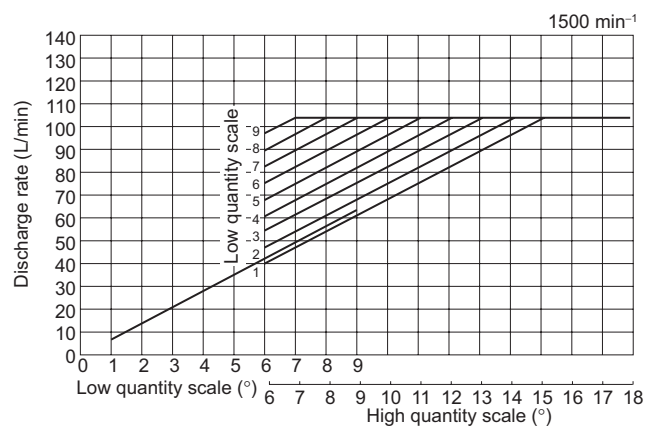

Contact Details

Before using the product, please check the guide pages at the front of this catalog.

Internet

<http://www.daikinpmc.com/en/>

For latest information, PDF catalogs and operation manuals

Pressure compensator characteristics

● Sharp cutoff characteristics

- The pressure gradient at cutoff is no greater than 0.5 MPa {5 kgf/cm²}
- Sharp and stable cutoff characteristics are achieved.

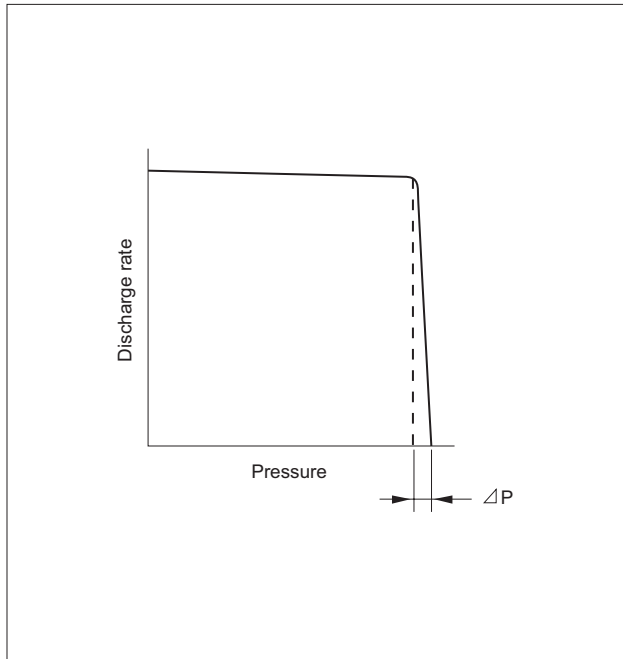

Response characteristics

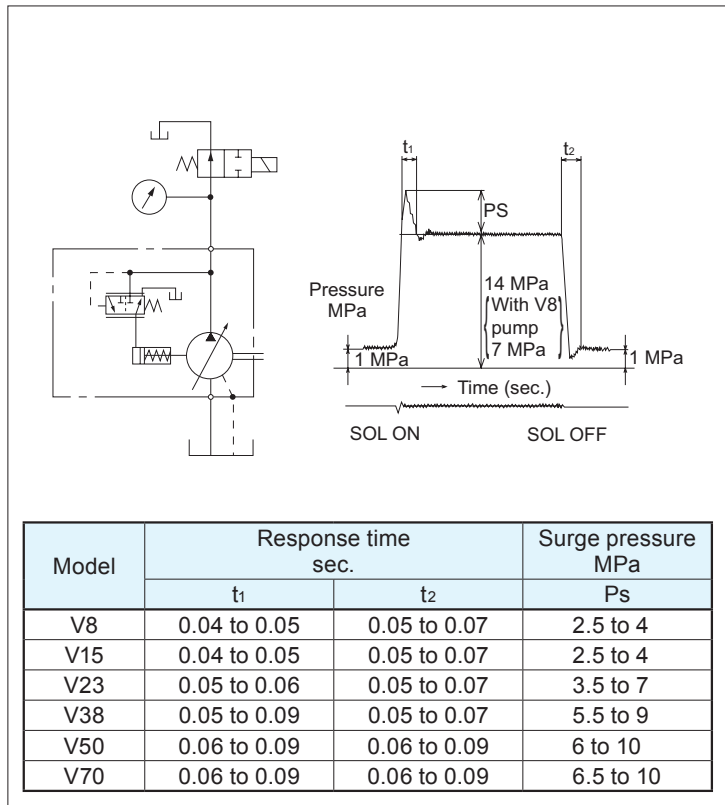

Noise characteristics (JIS B 8350, measuring position: 1 m from pump front)

Input rotational speed	Fluid used	Oil temperature
1800 min ⁻¹ 1500 min ⁻¹	Equivalent to ISO VG32	50°C

- At full-cutoff at 1800 min⁻¹
- × At full-cutoff at 1500 min⁻¹

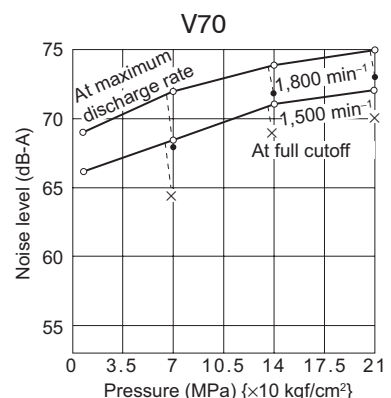
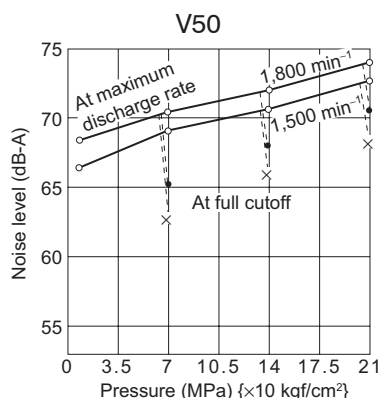
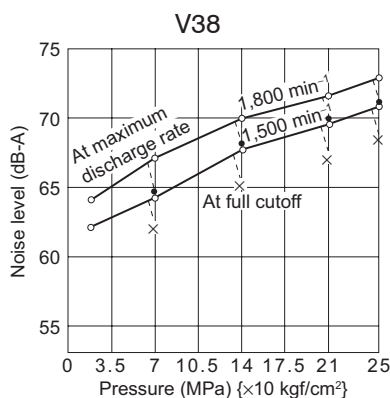
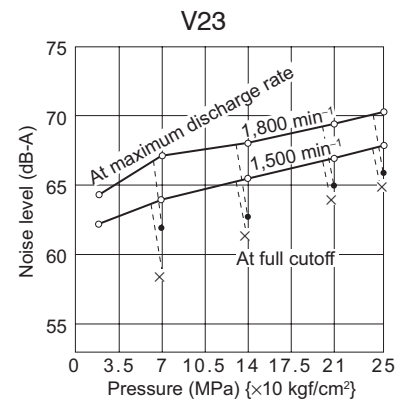
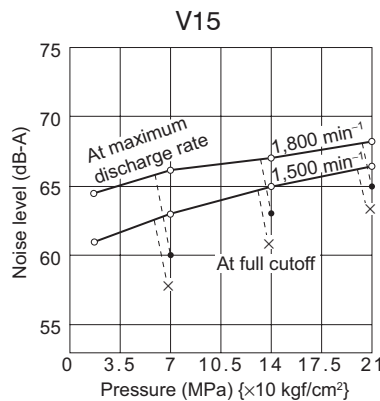
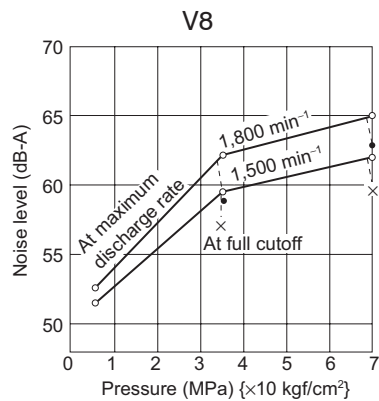

General performance

Discharge rate setting: maximum, Fluid used: ISO VG32, Fluid temperature: 50°C

1800 min⁻¹

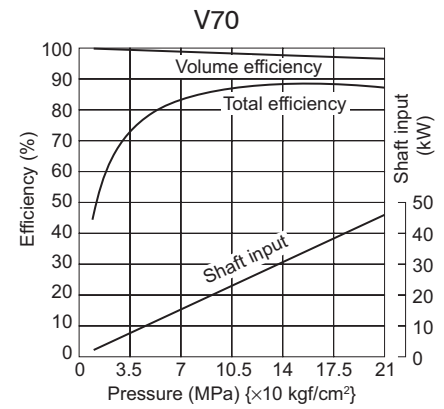
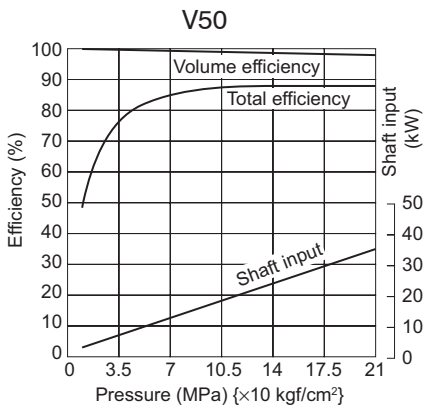
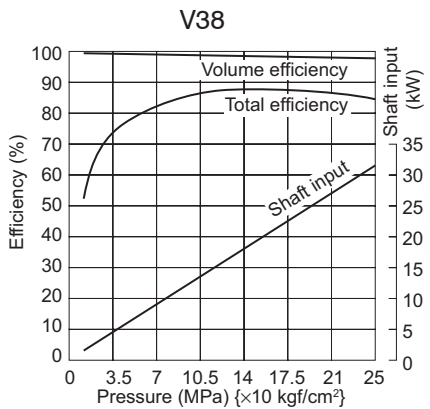
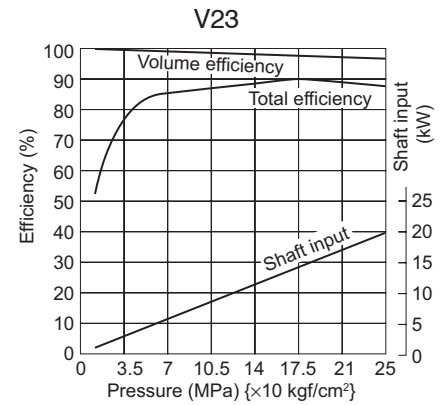
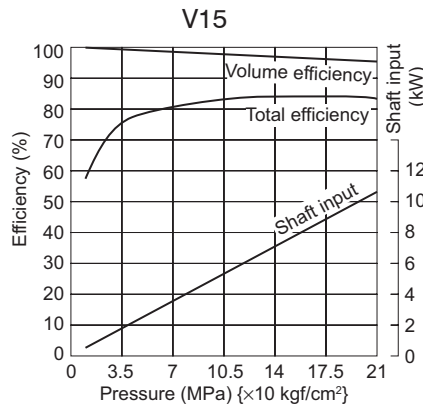
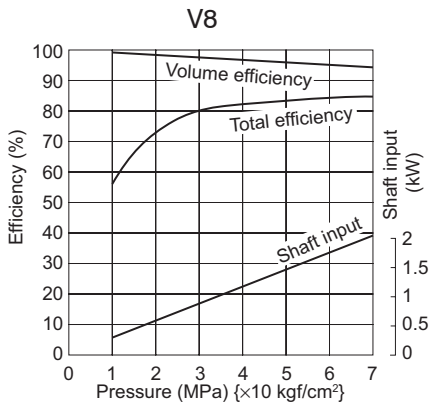

1500 min⁻¹

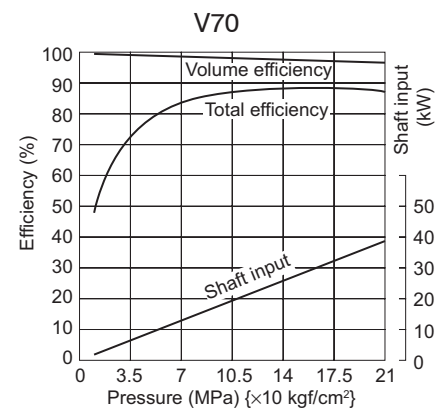
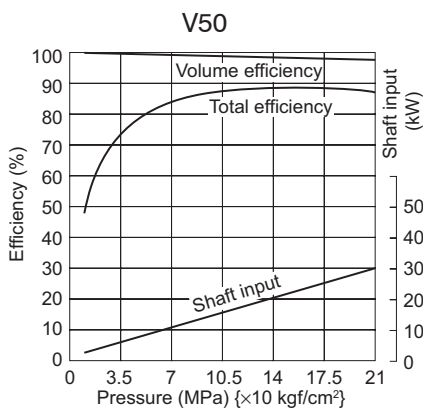
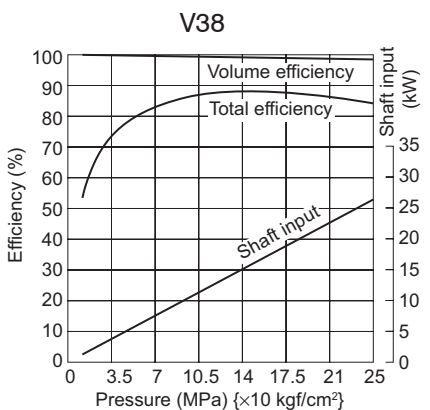
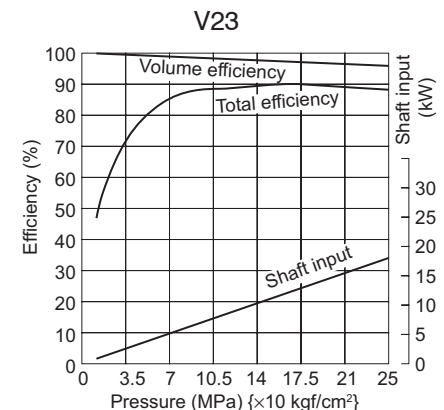
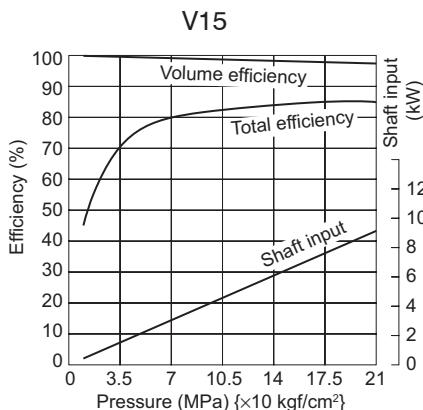
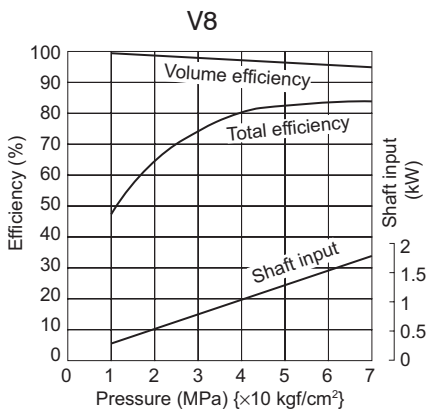

Note: The efficiency varies depending on the discharge rate setting. When selecting the motor capacity, refer to the shaft input characteristics on Page A-19.

Contact Details

Before using the product, please check the guide pages at the front of this catalog.

Internet

<http://www.daikinpmc.com/en/>

For latest information, PDF catalogs and operation manuals

Shaft input characteristics at full cutoff

Common to 1800 min⁻¹ and 1500 min⁻¹ Fluid used: ISO VG32, Fluid Temperature: 50°C

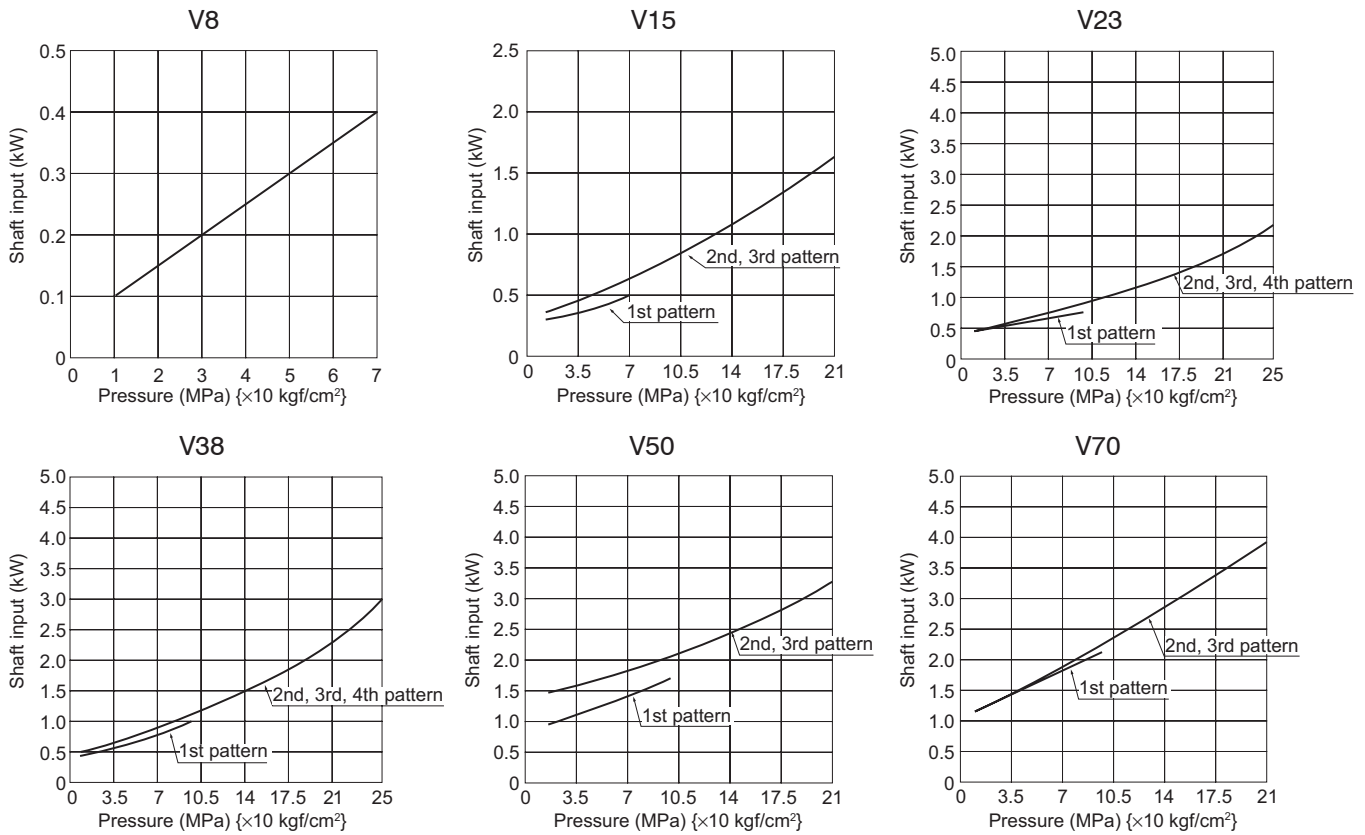

Contact Details

Before using the product, please check the guide pages at the front of this catalog.

Internet

<http://www.daikinpmc.com/en/>

For latest information, PDF catalogs and operation manuals

Shaft input characteristics

Common to 1800 min⁻¹ and 1500 min⁻¹ Fluid used: ISO VG32, Fluid Temperature: 50°C

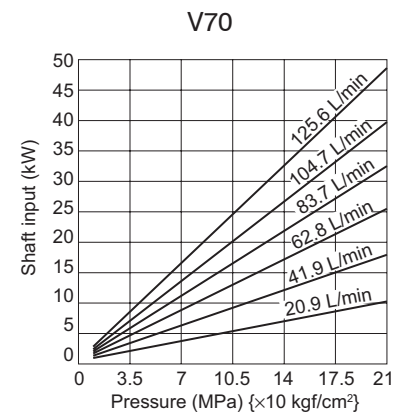
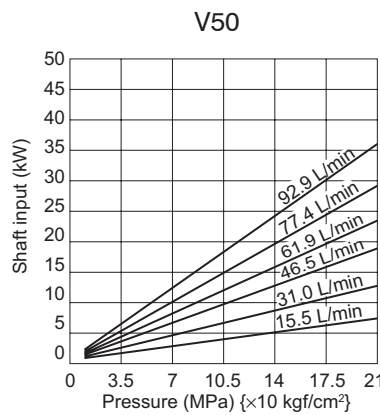
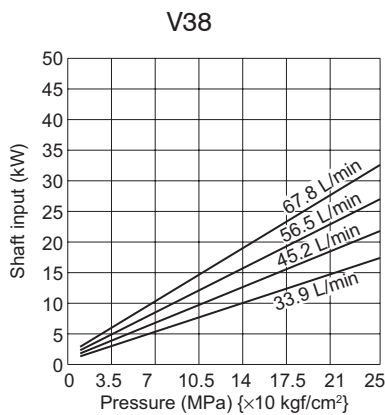
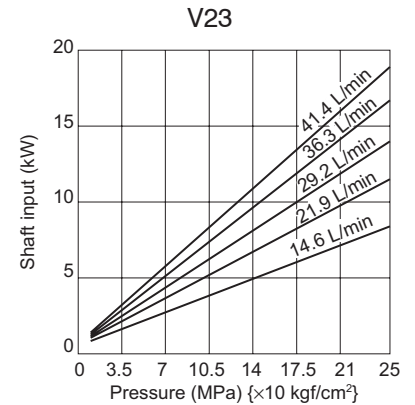
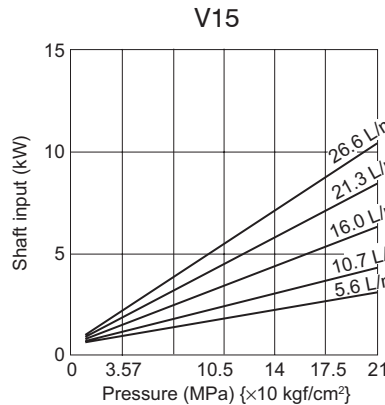
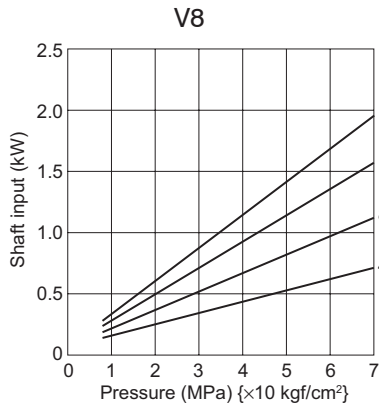

Drainage volume characteristics

Common to 1800 min⁻¹ and 1500 min⁻¹ Fluid used: ISO VG32, Fluid Temperature: 50°C

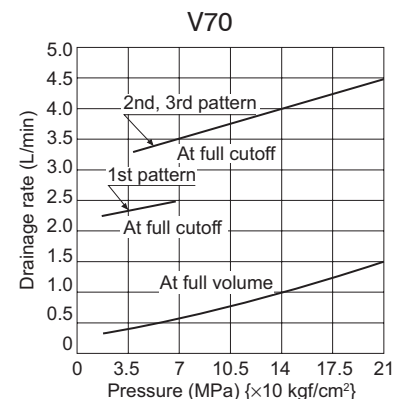
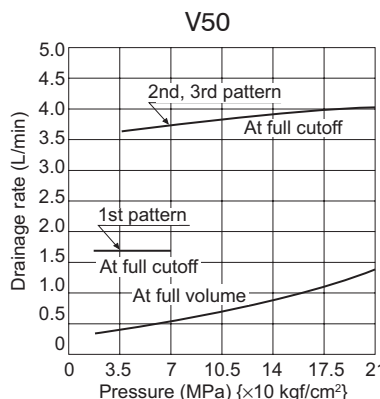
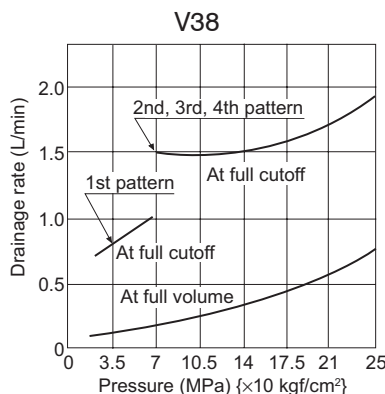
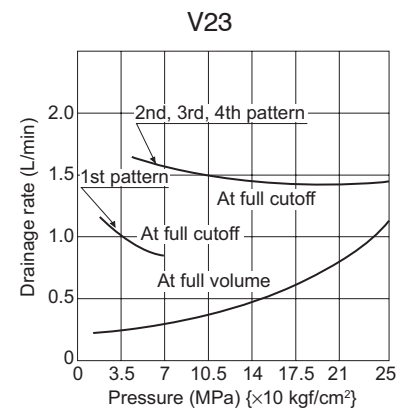
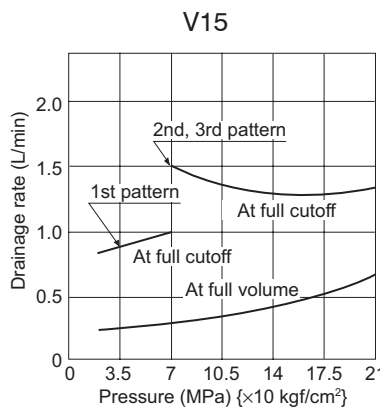
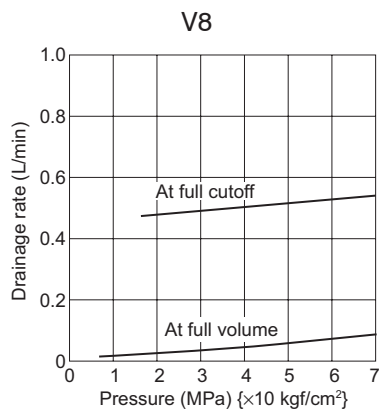

Contact Details

Before using the product, please check the guide pages at the front of this catalog.

Internet

<http://www.daikinpmc.com/en/>

For latest information, PDF catalogs and operation manuals

External dimension diagram

V8A1RX-20

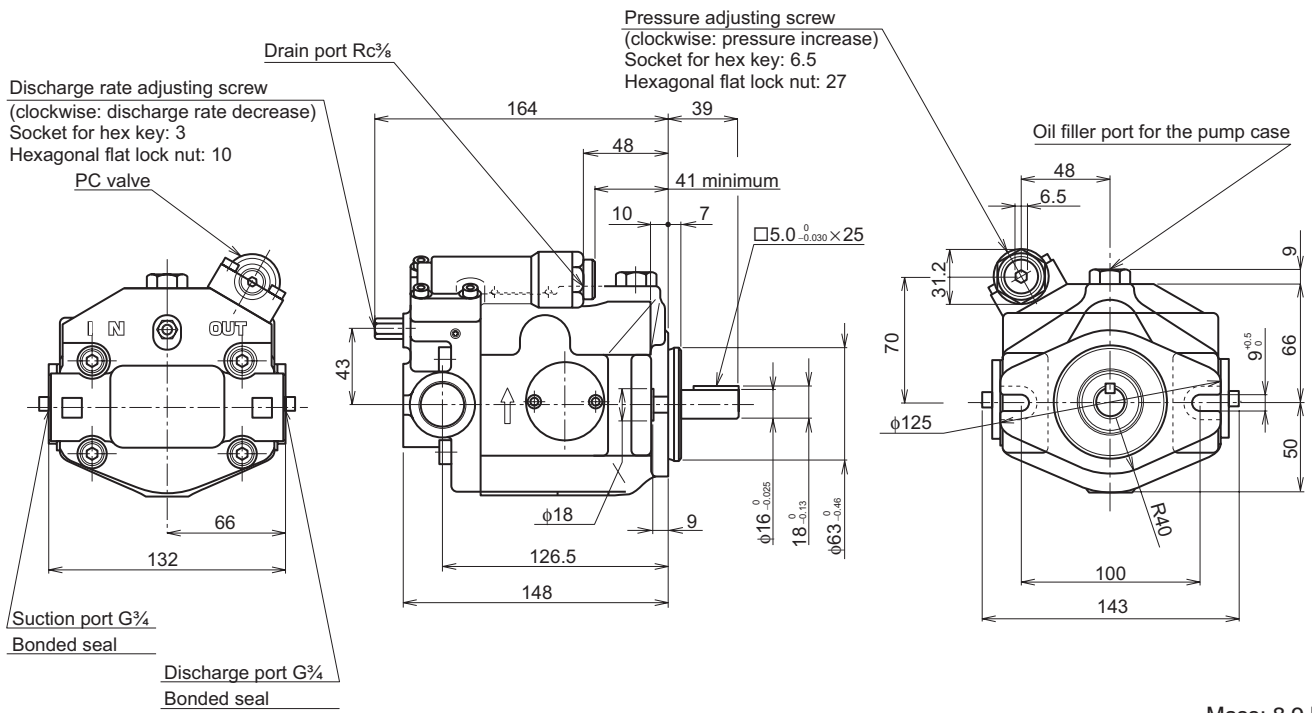

Contact Details

Before using the product, please check the guide pages at the front of this catalog.

Internet

<http://www.daikinpmc.com/en/>

For latest information, PDF catalogs and operation manuals

External dimension diagram

V15A3R-95RC

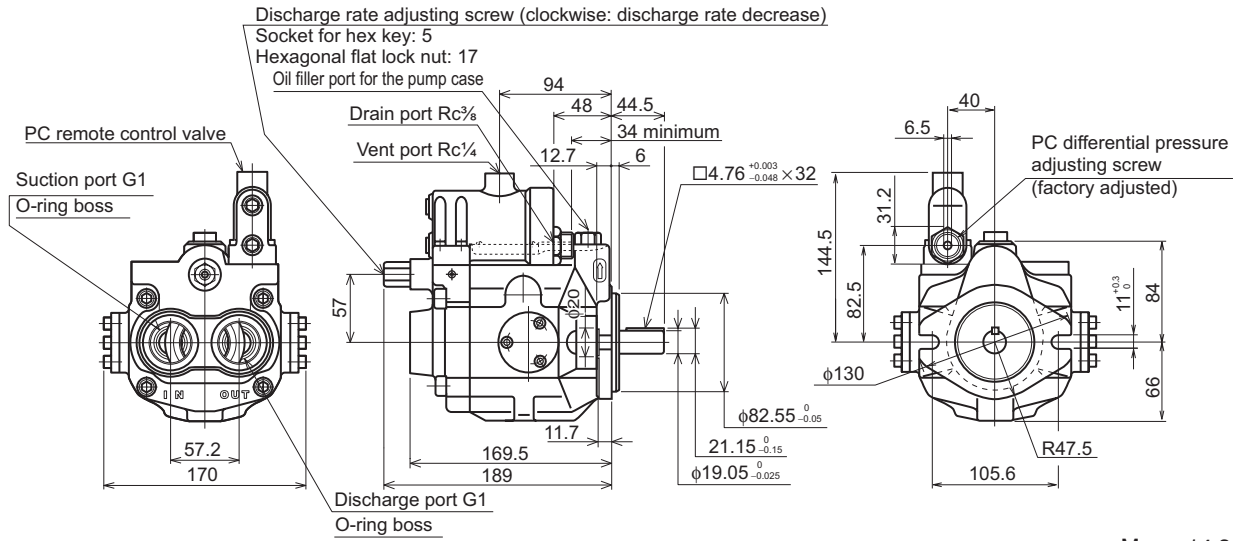

Mass: 14.3 kg

V15C \times RHX-95

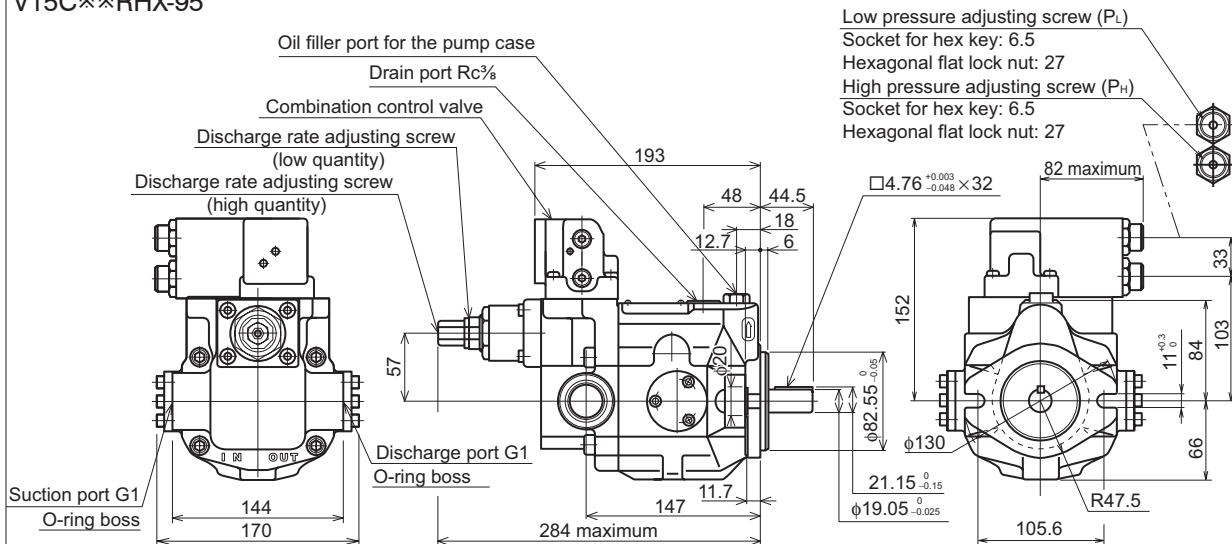

Mass: 17.6 kg

V15C \times 3RHX-95RC

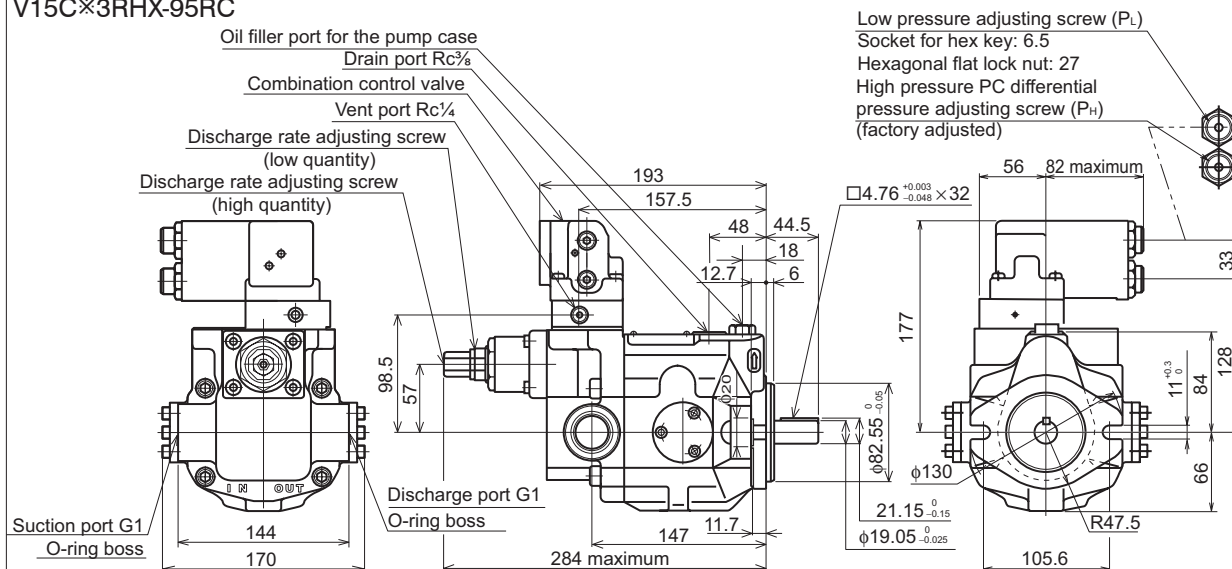

Mass: 18.4 kg

External dimension diagram

V15CRJ**X-95**

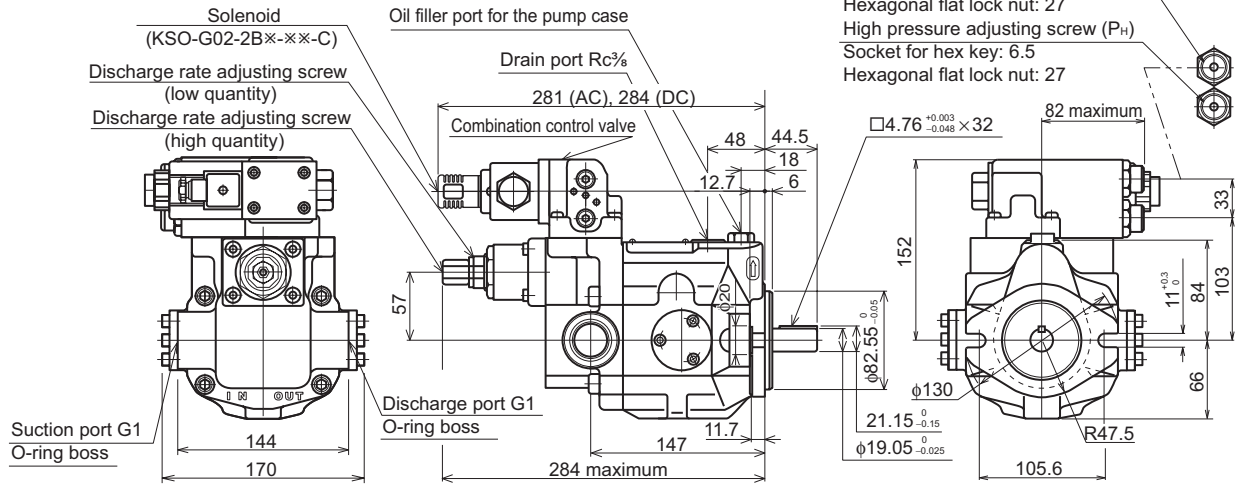

Mass: 19.3 kg

V15C*3RJ*X-95RC

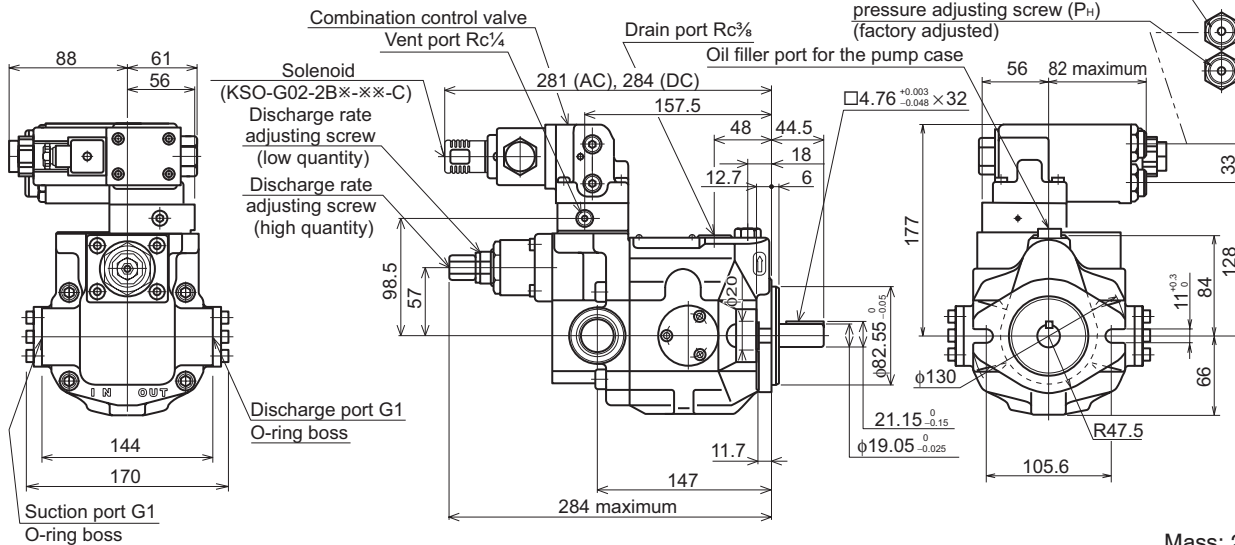

Mass: 20.1 kg

V15DR**X-95**

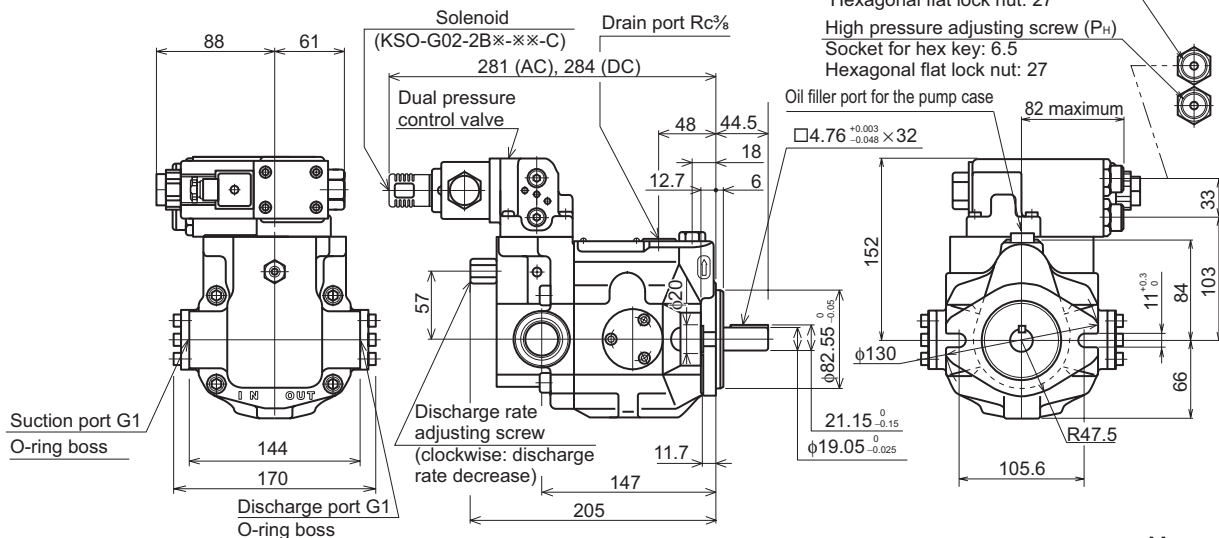

Mass: 17.8 kg

Contact Details

Before using the product, please check the guide pages at the front of this catalog.

Internet

<http://www.daikinpmc.com/en/>

For latest information, PDF catalogs and operation manuals

External dimension diagram

V15A1RY-95

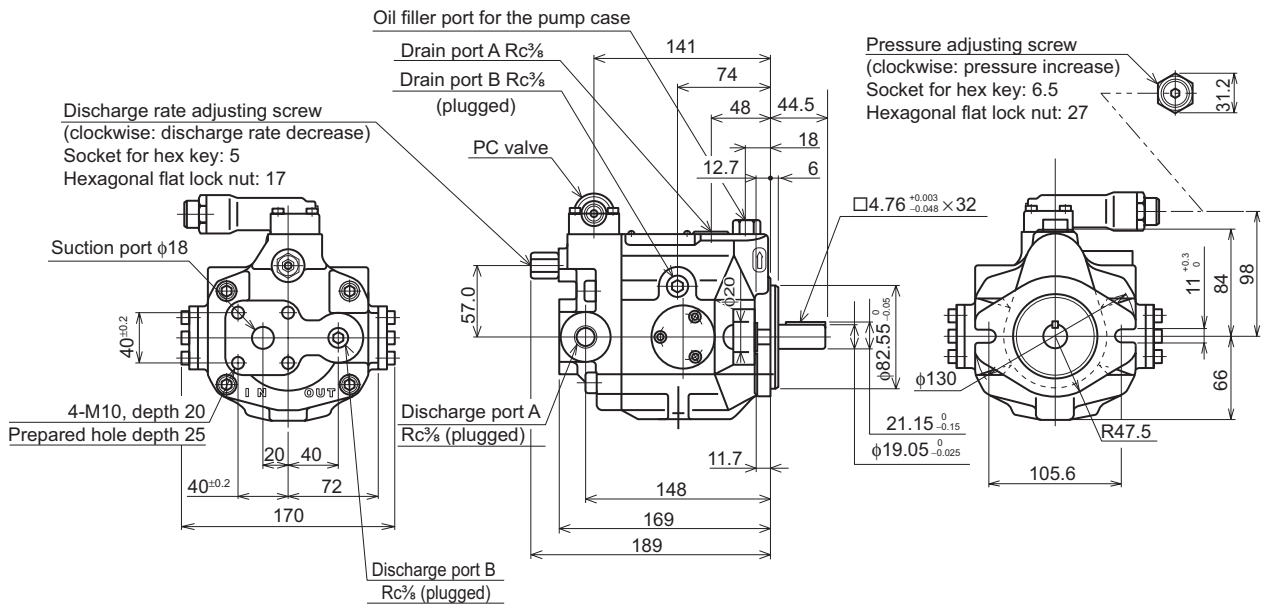

Mass: 13.5 kg

* Use SHA15 or SSA20 pipe flange (JIS B 2291) or equivalent at the suction side.

Contact Details

Before using the product, please check the guide pages at the front of this catalog.

Internet

<http://www.daikinpmc.com/en/>

For latest information, PDF catalogs and operation manuals

External dimension diagram

V23A×RX-30

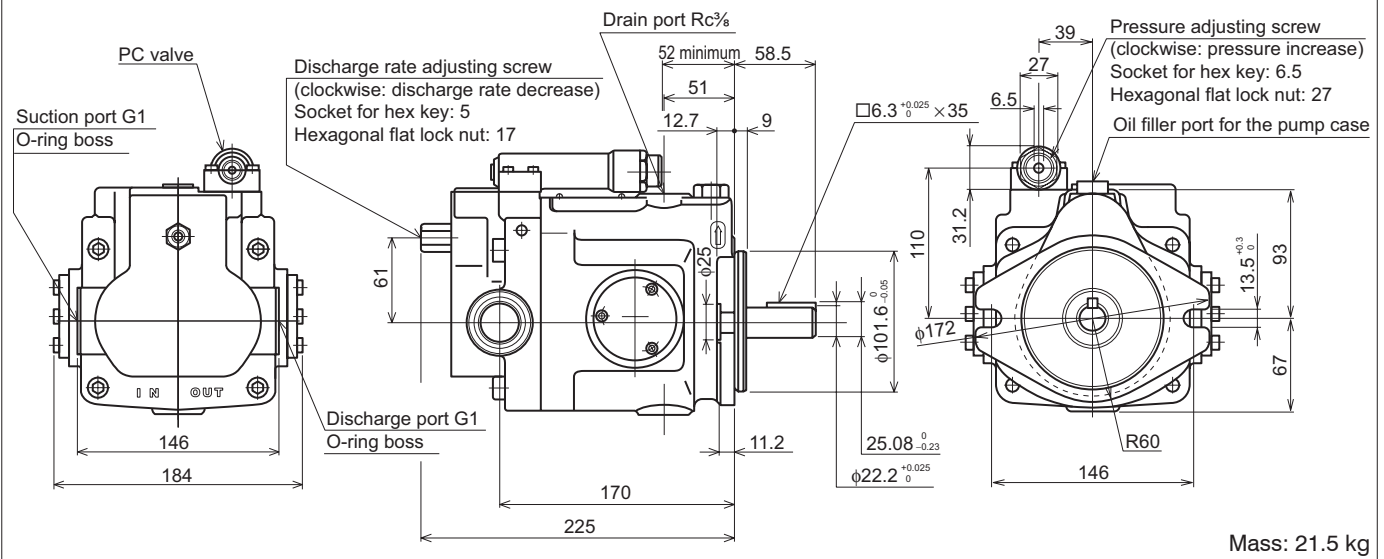

V23A×R-30

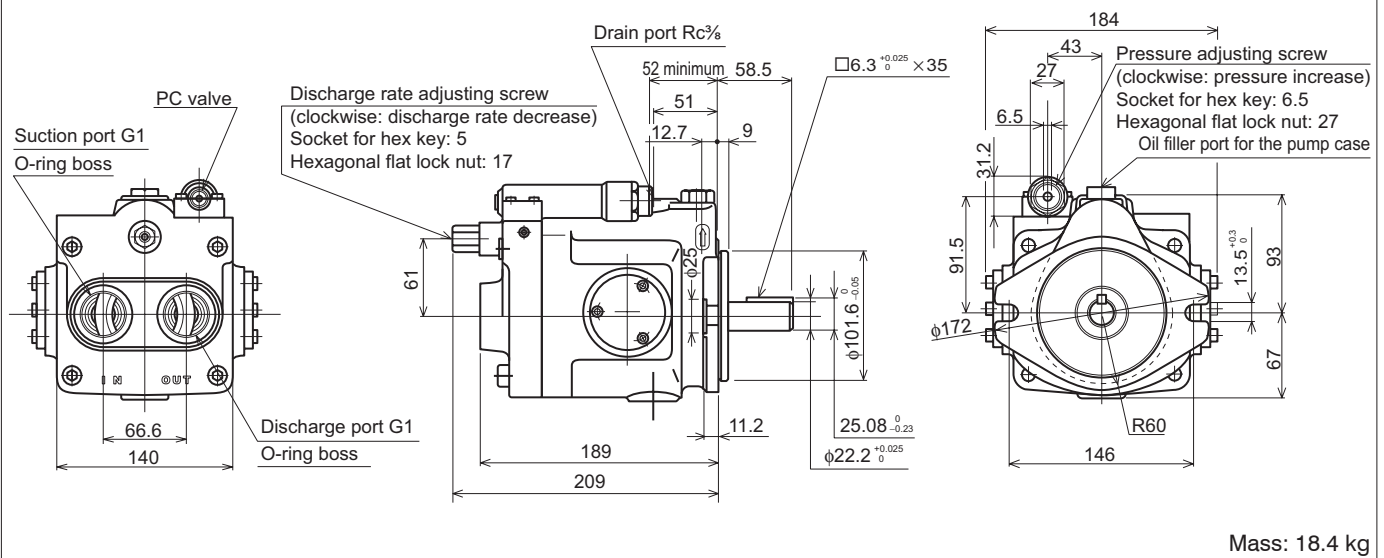

V23A4RX-30RC

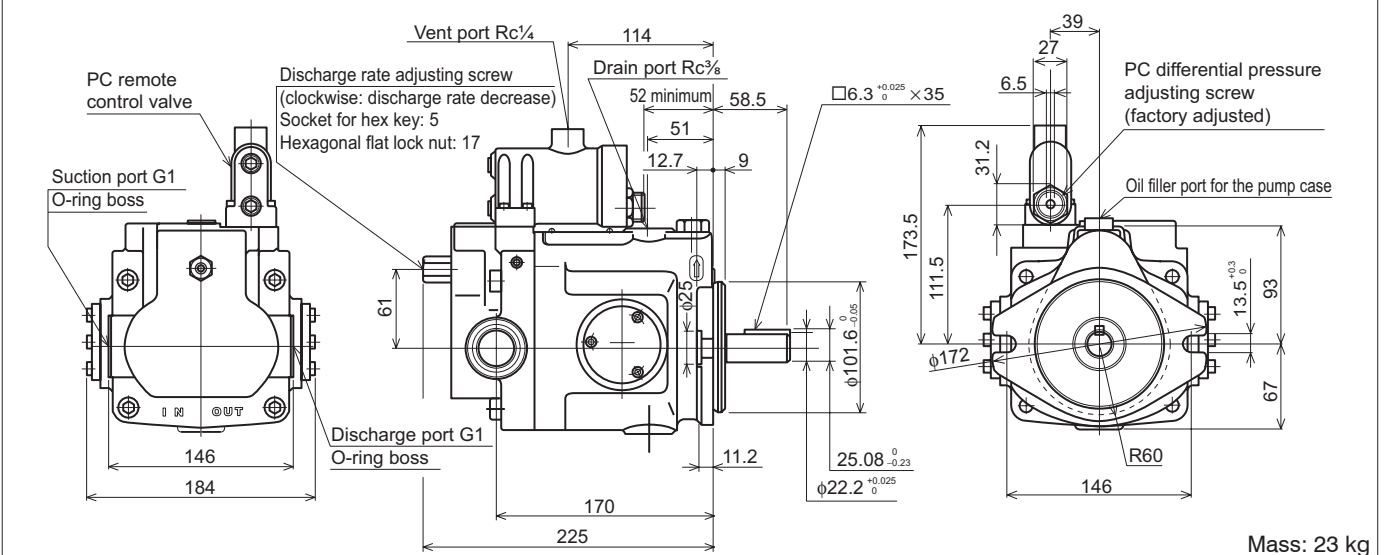

External dimension diagram

V23A4R-30RC

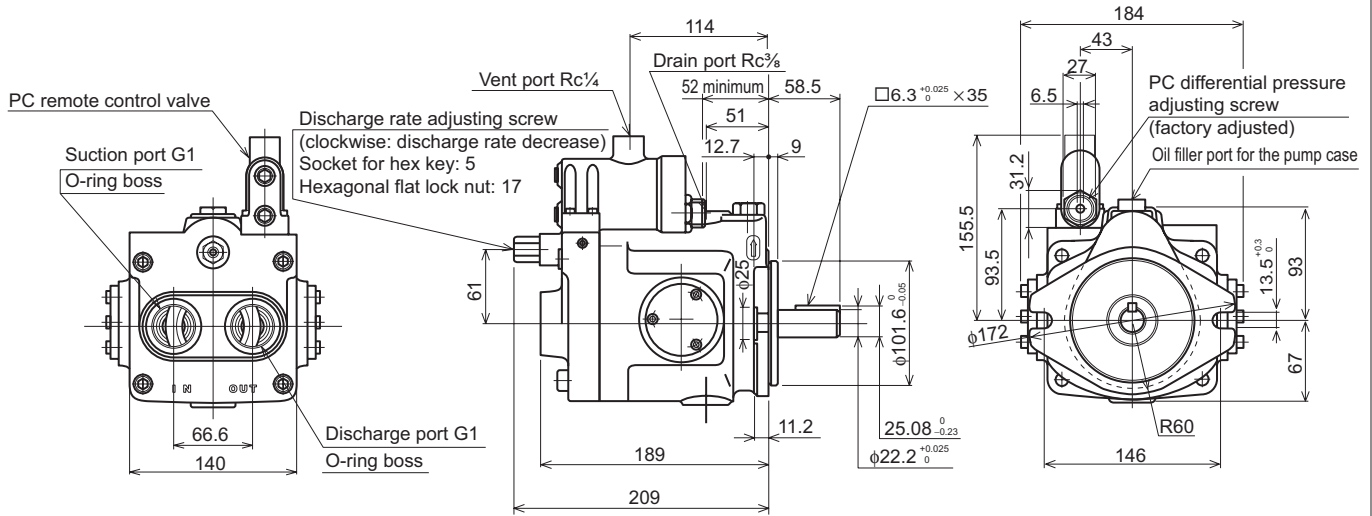

Mass: 20 kg

V23C××RHX-30

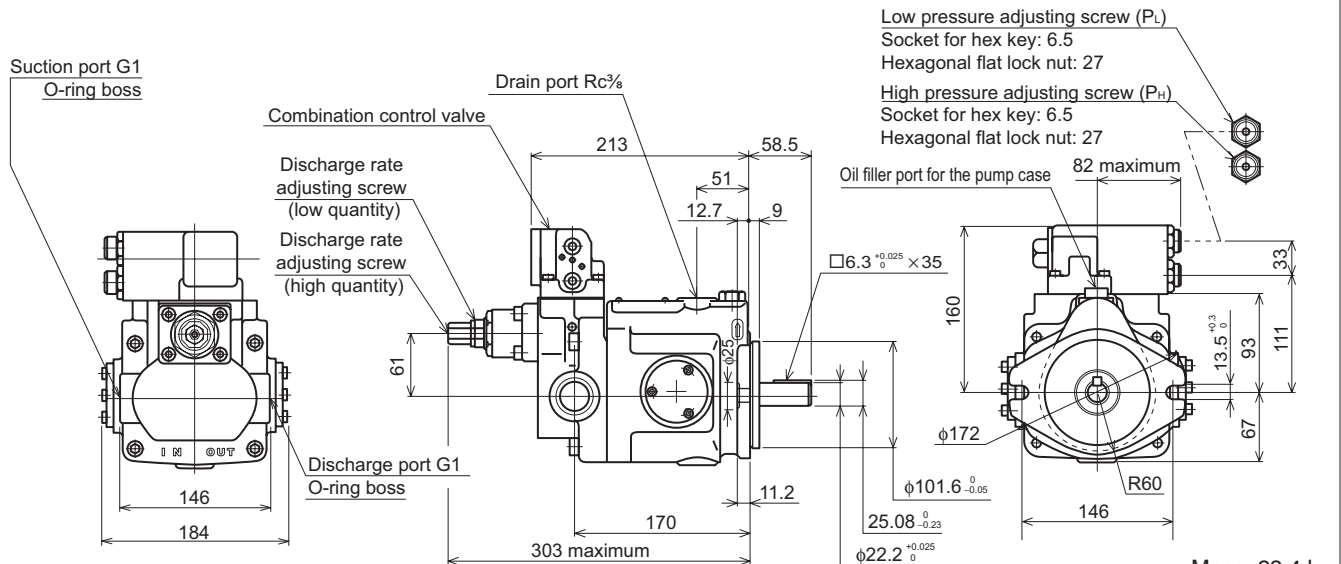

Mass: 23.4 kg

V23C×4RHX-30RC

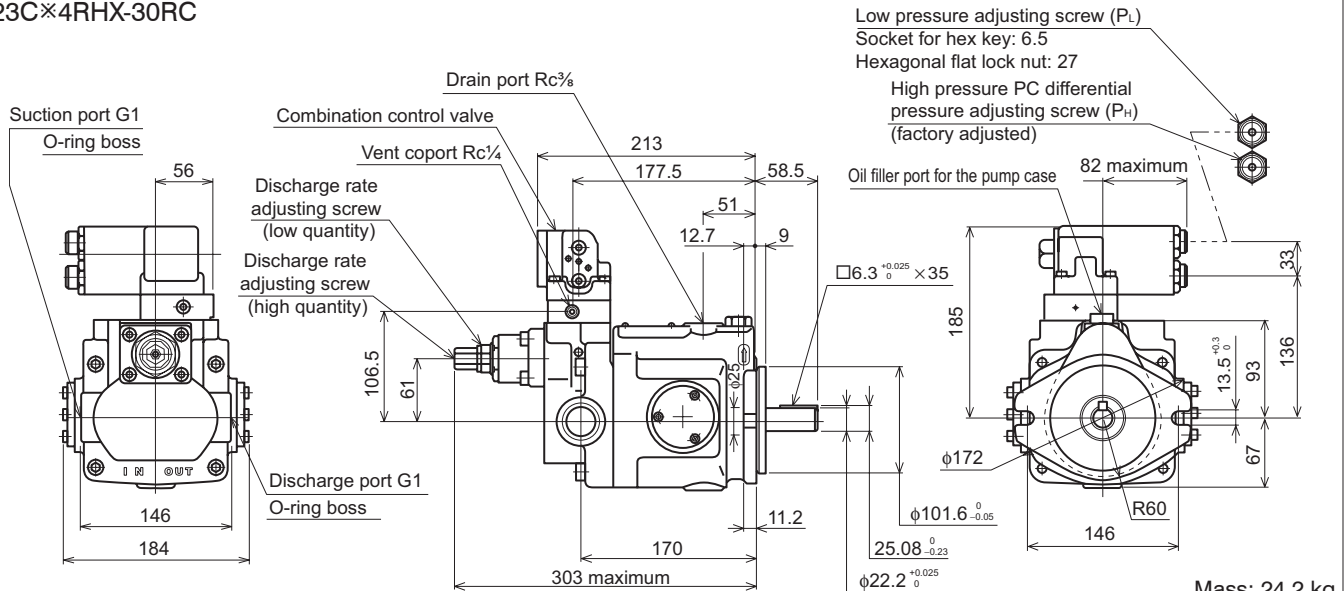

Mass: 24.2 kg

Contact Details

Before using the product, please check the guide pages at the front of this catalog.

Internet

<http://www.daikinpmc.com/en/>

For latest information, PDF catalogs and operation manuals

External dimension diagram

V23C※※RJ※X-35

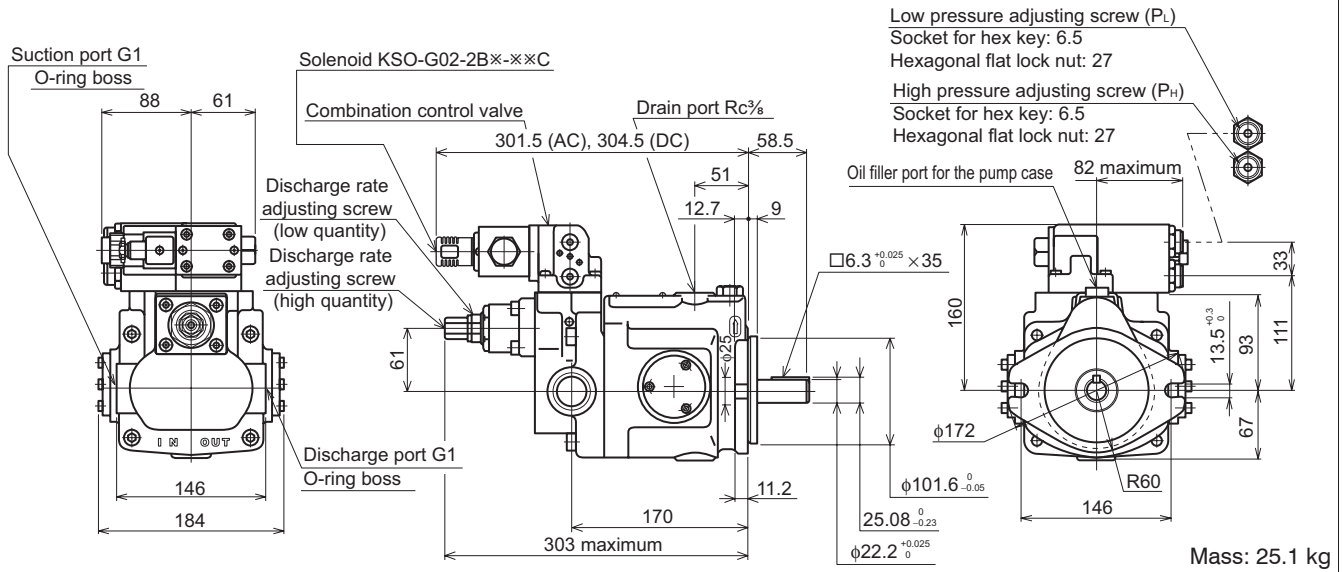

V23C※4RJ※X-35RC

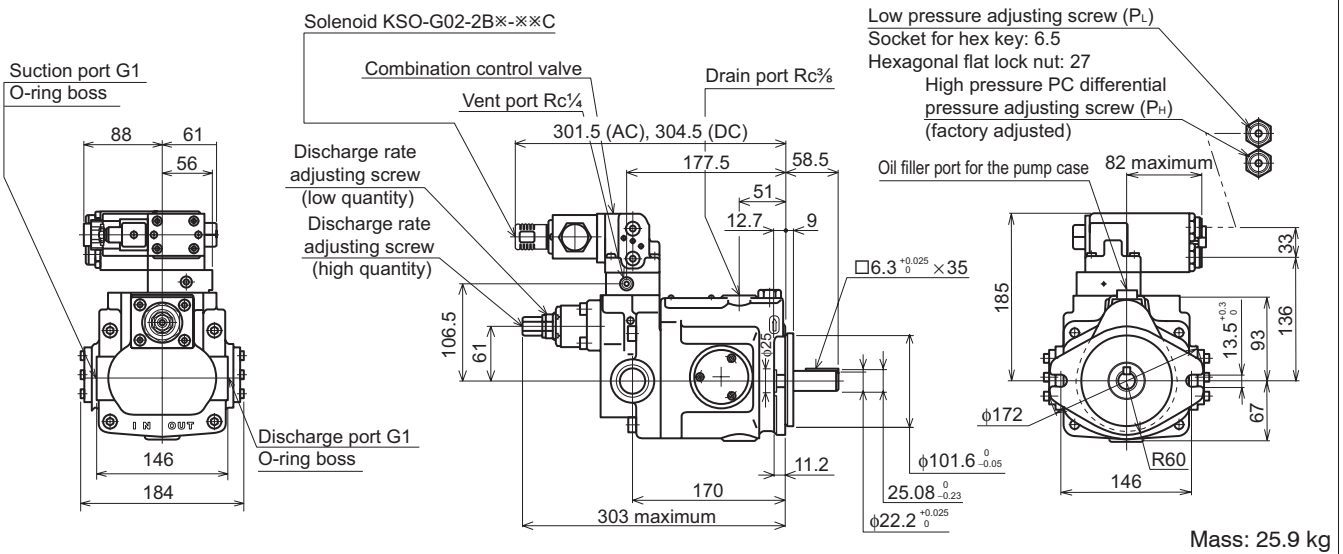

V23D※※R※X-35

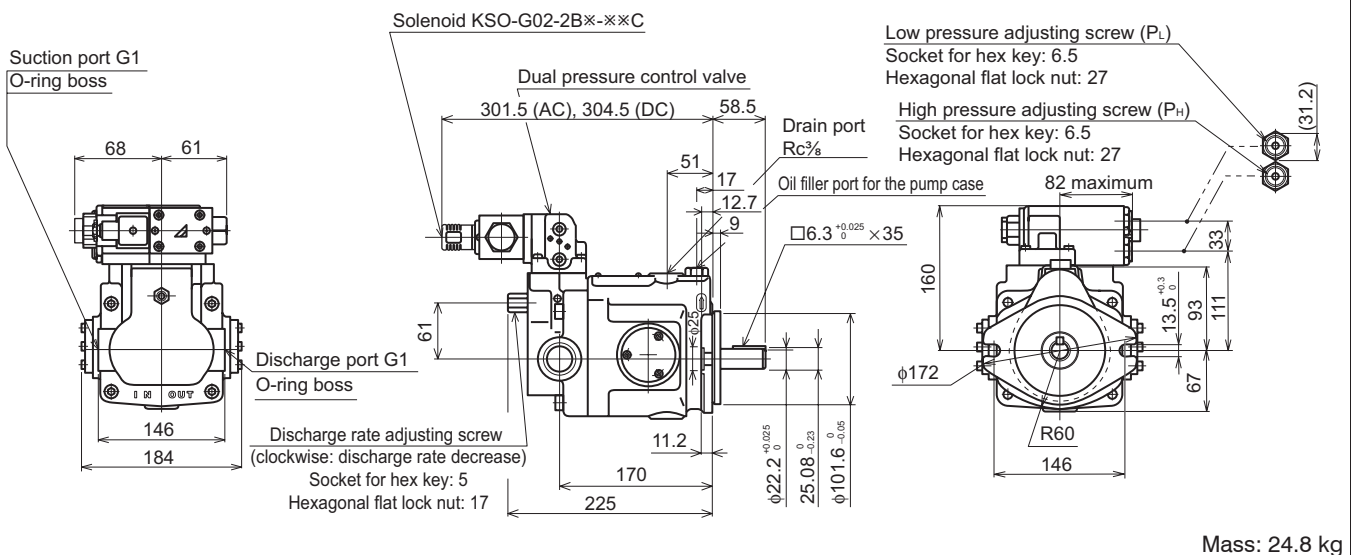

Contact Details

Before using the product, please check the guide pages at the front of this catalog.

Internet

<http://www.daikinpmc.com/en/>

For latest information, PDF catalogs and operation manuals

External dimension diagram

V23SAJS-※RX-30

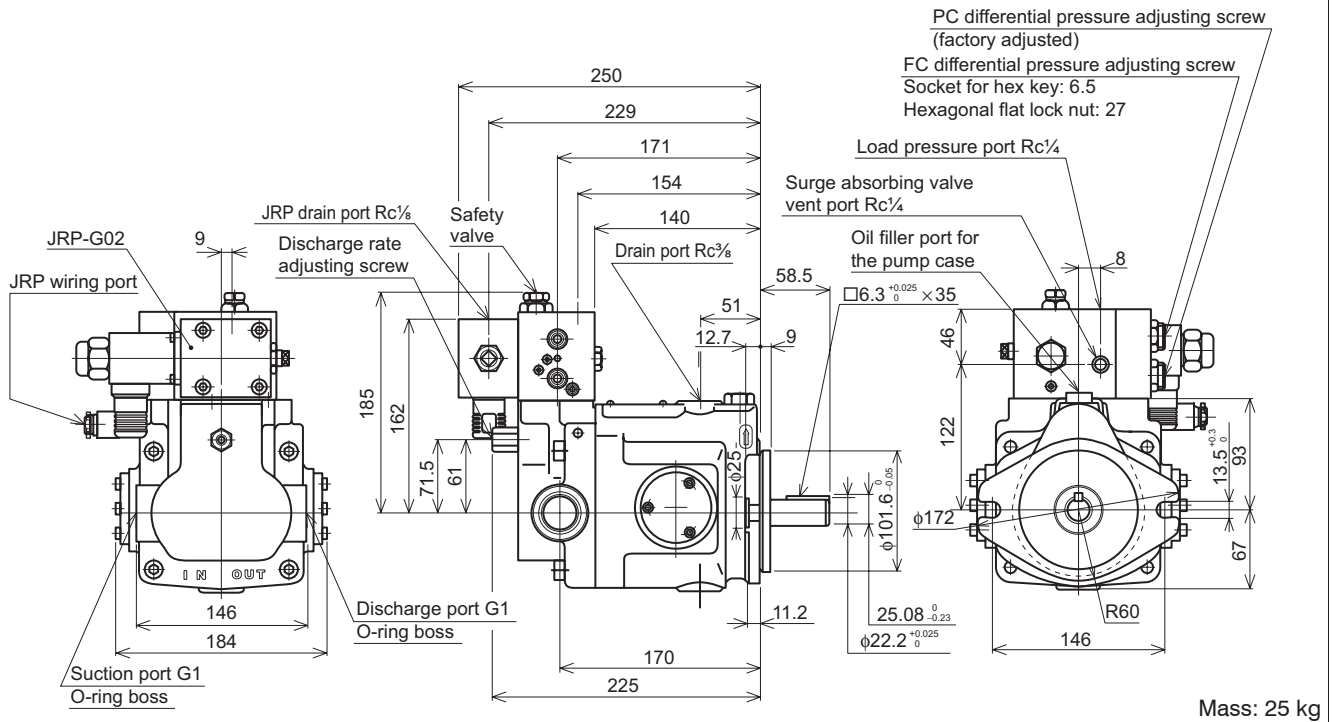

Contact Details

Before using the product, please check the guide pages at the front of this catalog.

Internet

<http://www.daikinpmc.com/en/>

For latest information, PDF catalogs and operation manuals

External dimension diagram

V38A×RX-95

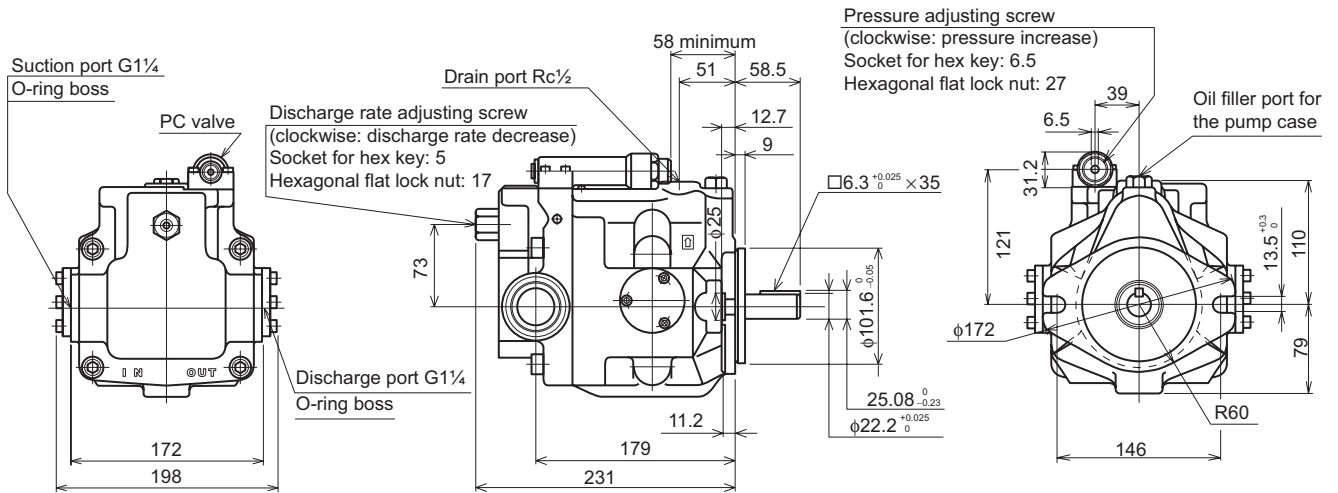

Mass: 26 kg

V38A×R-95

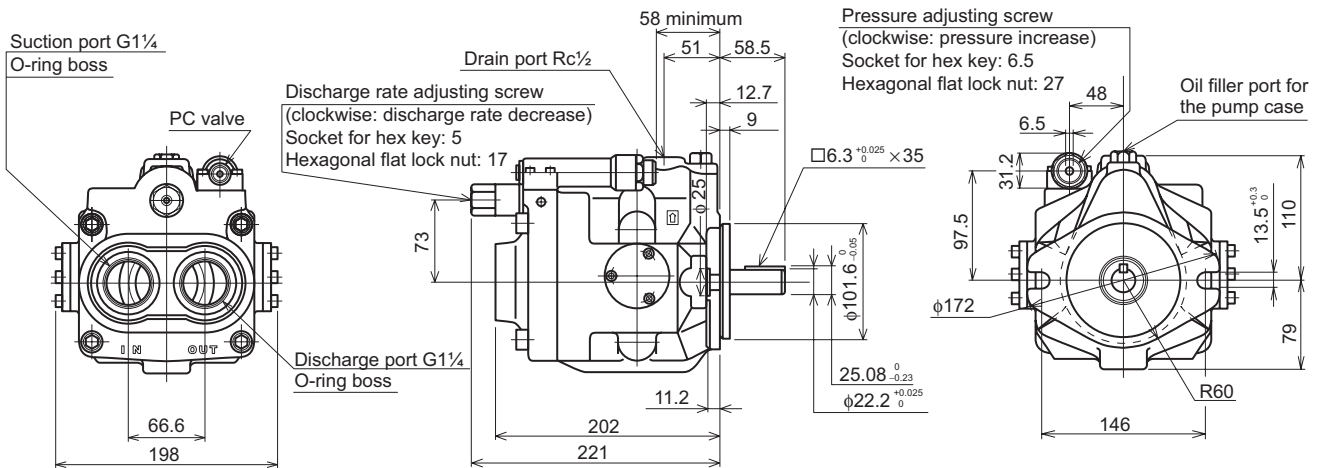

Mass: 24.4 kg

V38A4RX-95RC

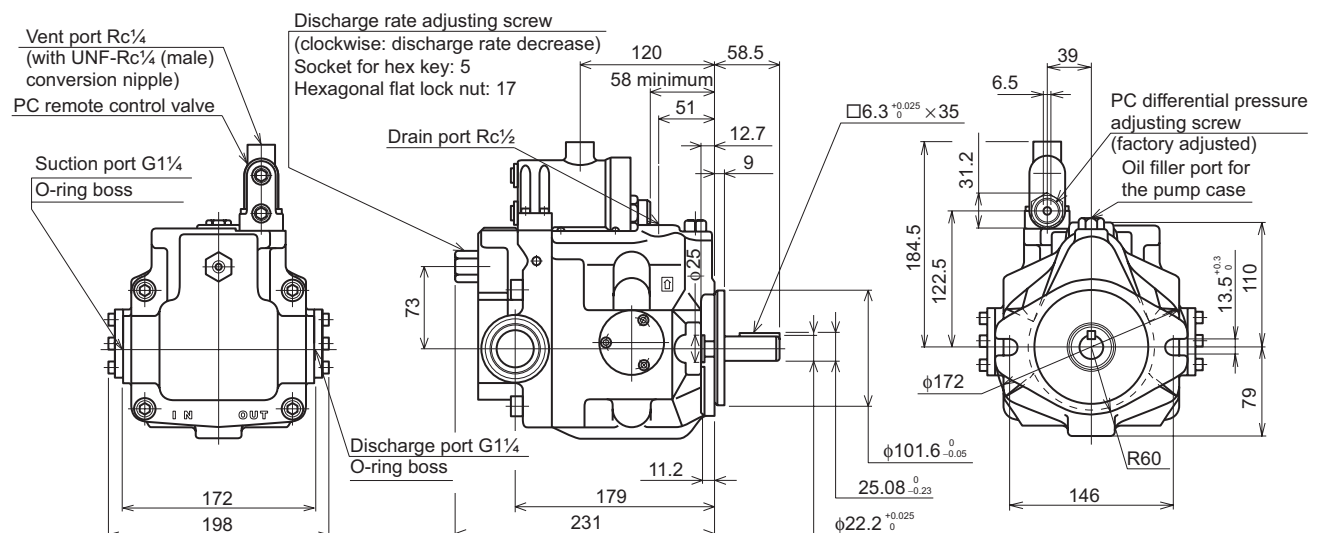

Mass: 28.7 kg

Contact Details

Before using the product, please check the guide pages at the front of this catalog.

Internet

<http://www.daikinpmc.com/en/>

For latest information, PDF catalogs and operation manuals

External dimension diagram

V38A4R-95RC

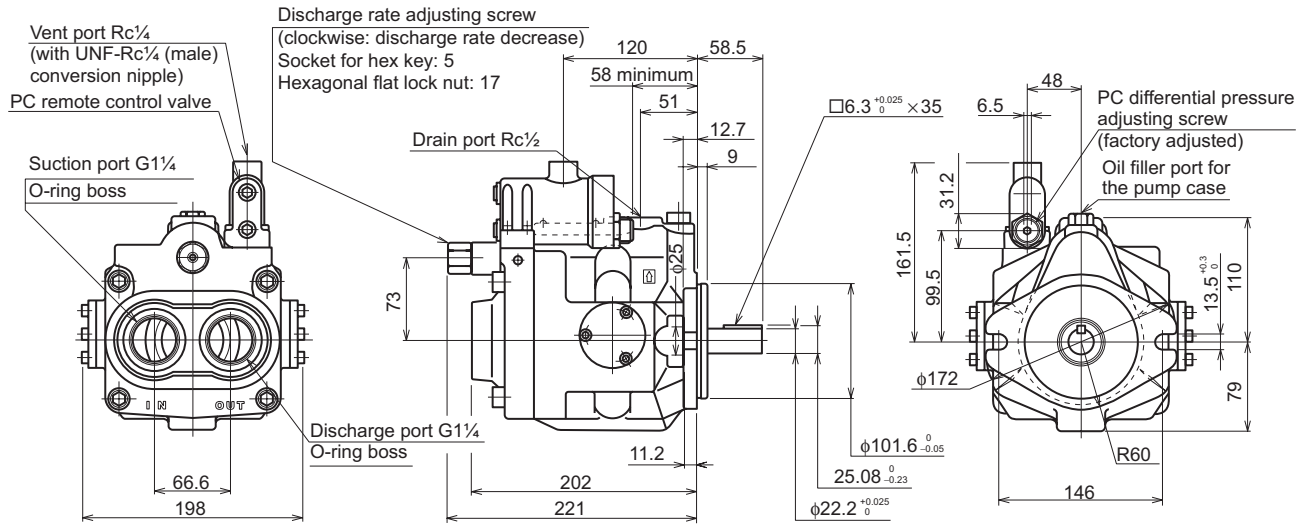

Mass: 26 kg

V38C×RHX-95

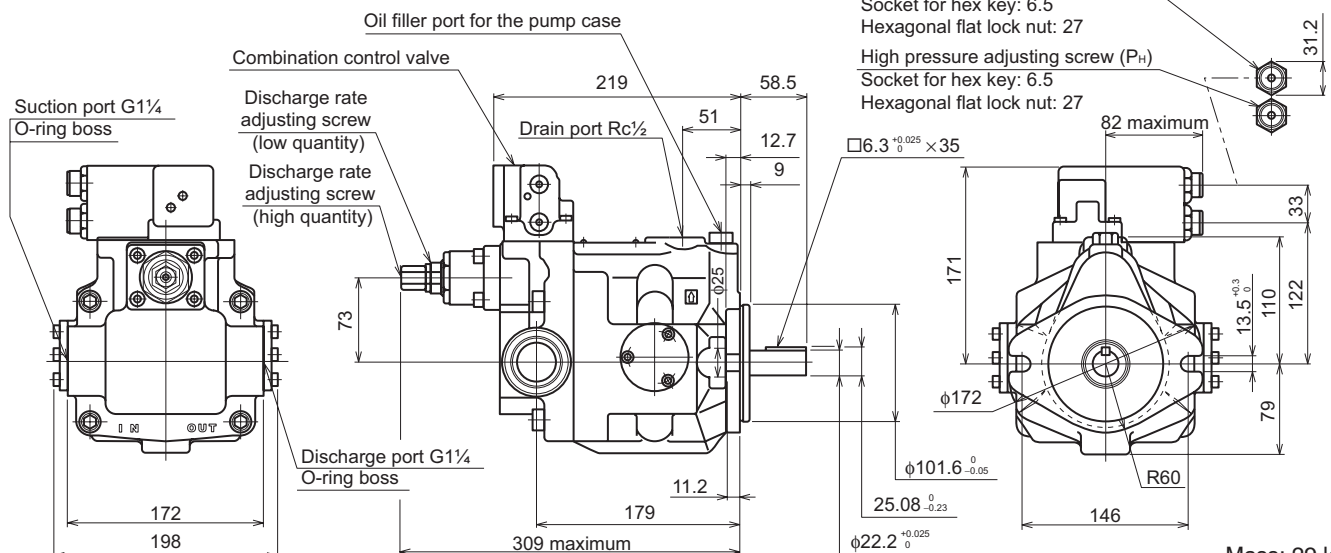

Mass: 29 kg

V38C×4RHX-95RC

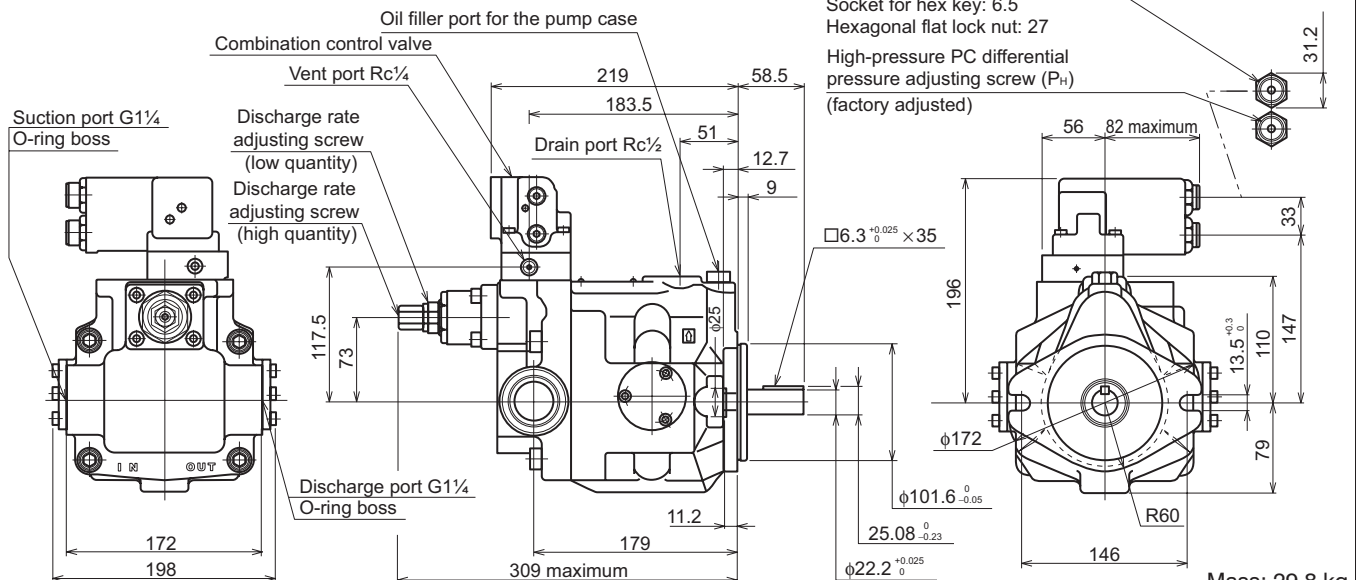

Mass: 29.8 kg

Contact Details

Before using the product, please check the guide pages at the front of this catalog.

Internet

<http://www.daikinpmc.com/en/>

For latest information, PDF catalogs and operation manuals

External dimension diagram

V38C××RJ×X-95

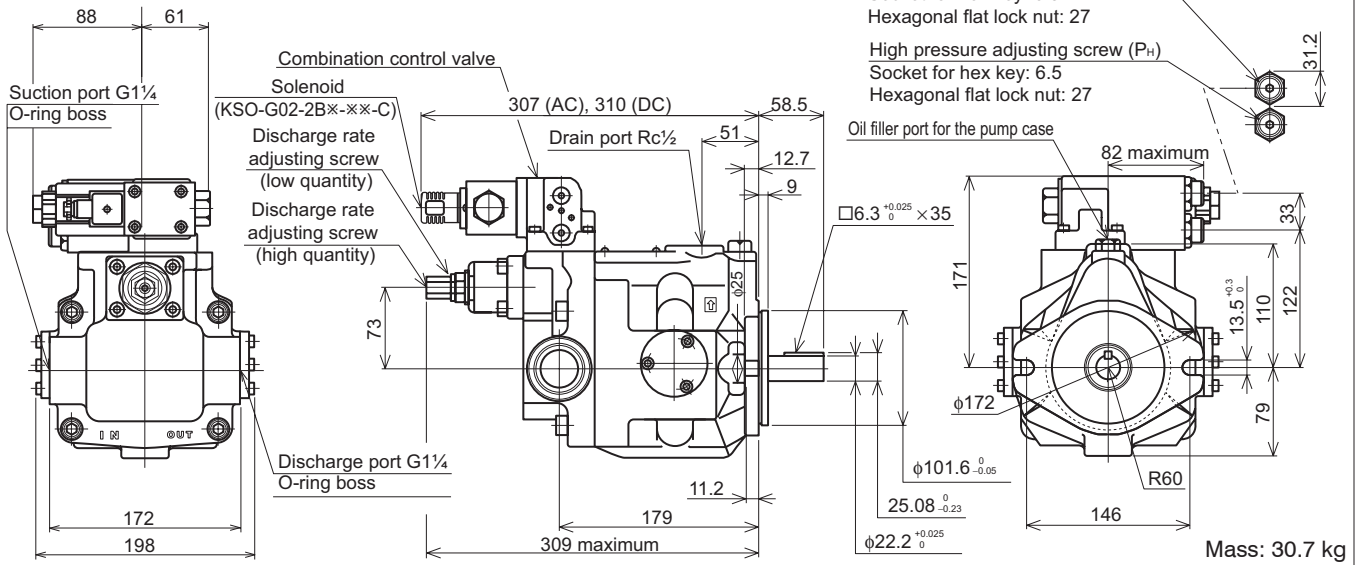

V38C×4RJ×X-95RC

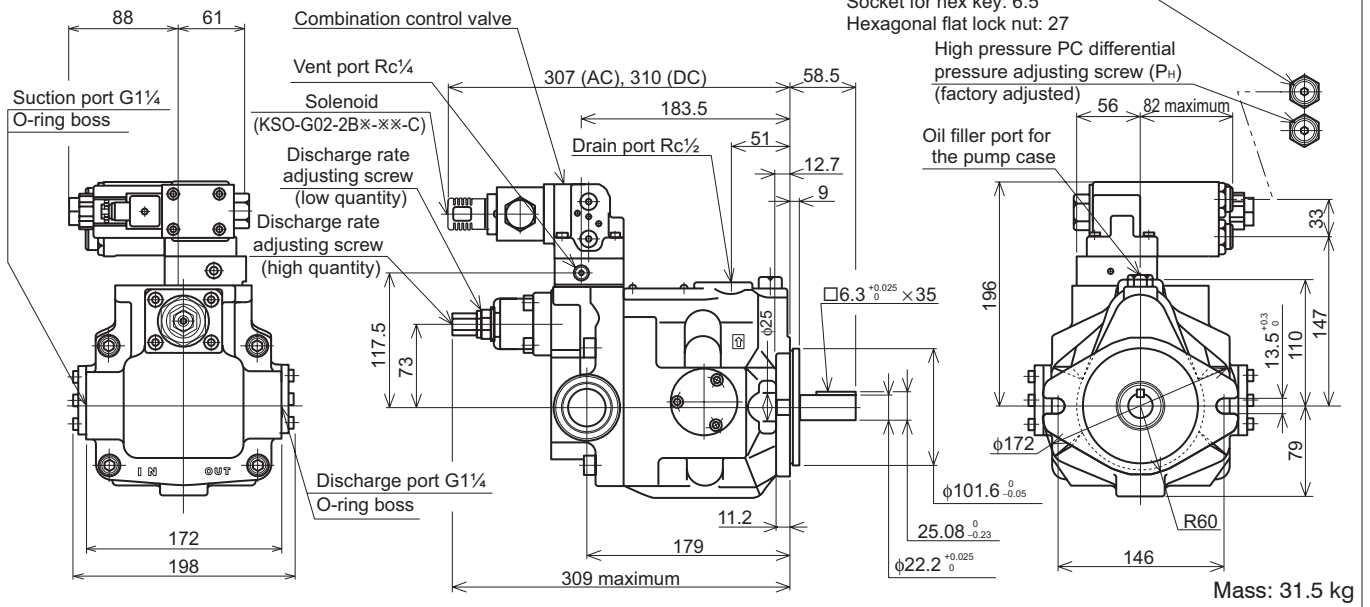

V38D××R×X-95

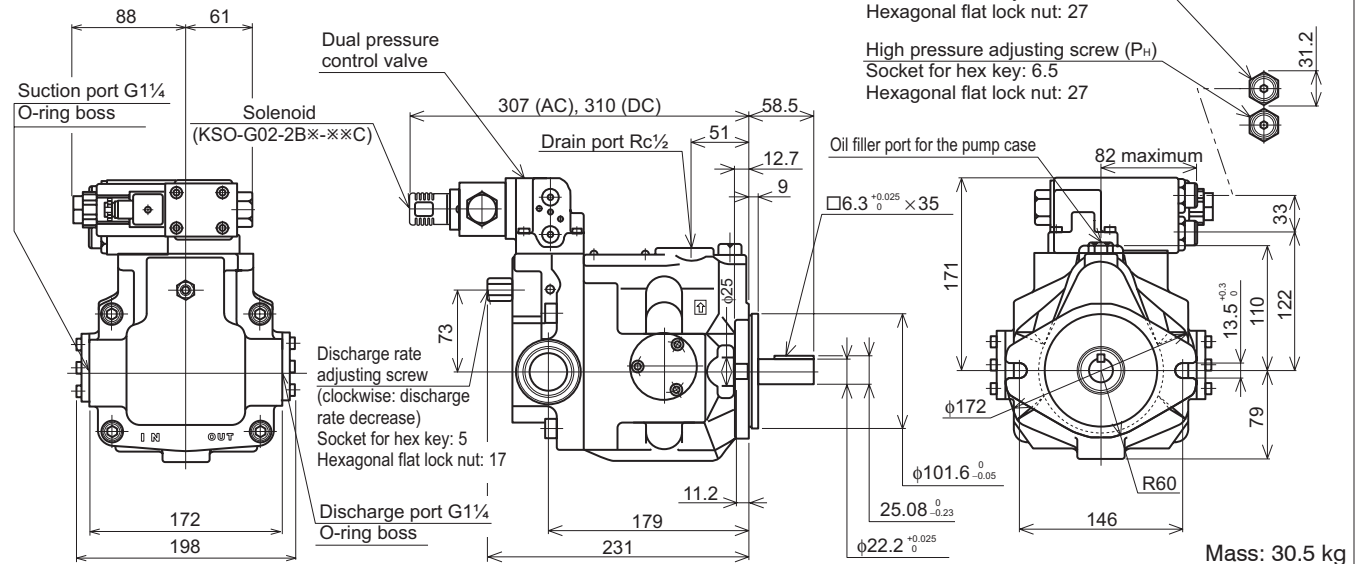

Contact Details

Before using the product, please check the guide pages at the front of this catalog.

Internet

<http://www.daikinpmc.com/en/>

For latest information, PDF catalogs and operation manuals

External dimension diagram

V38D×4R×X-95RC

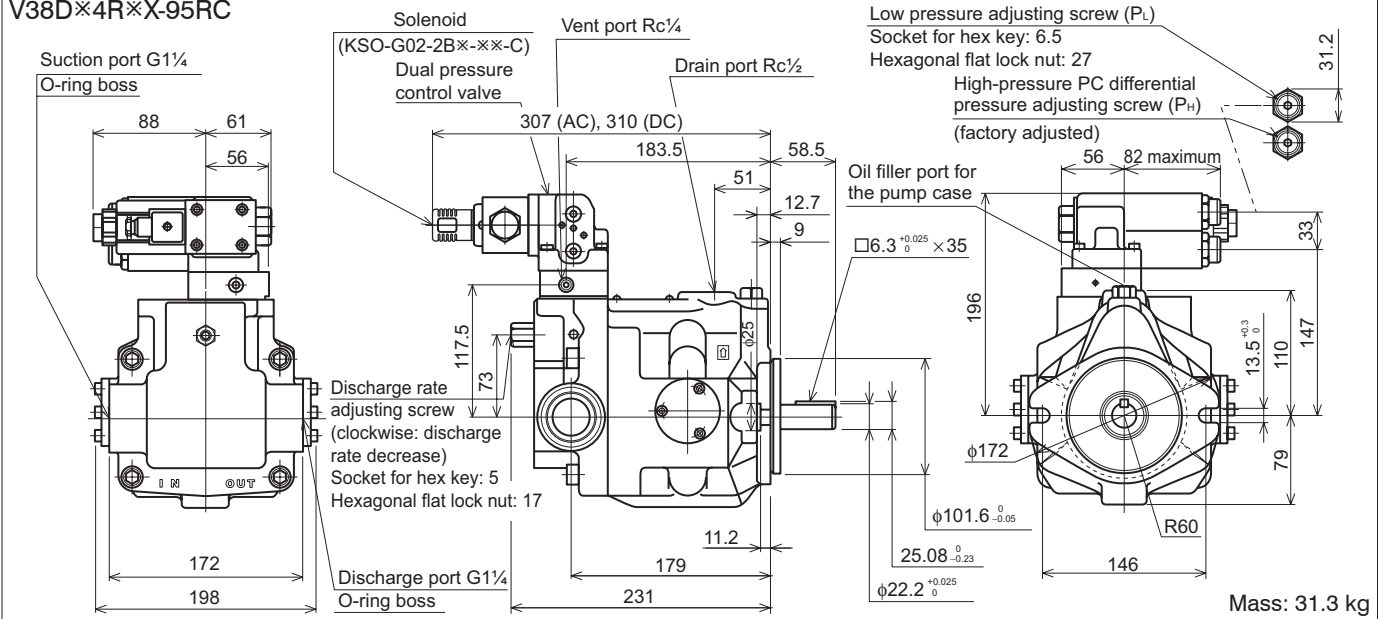

V38SA×RX-95

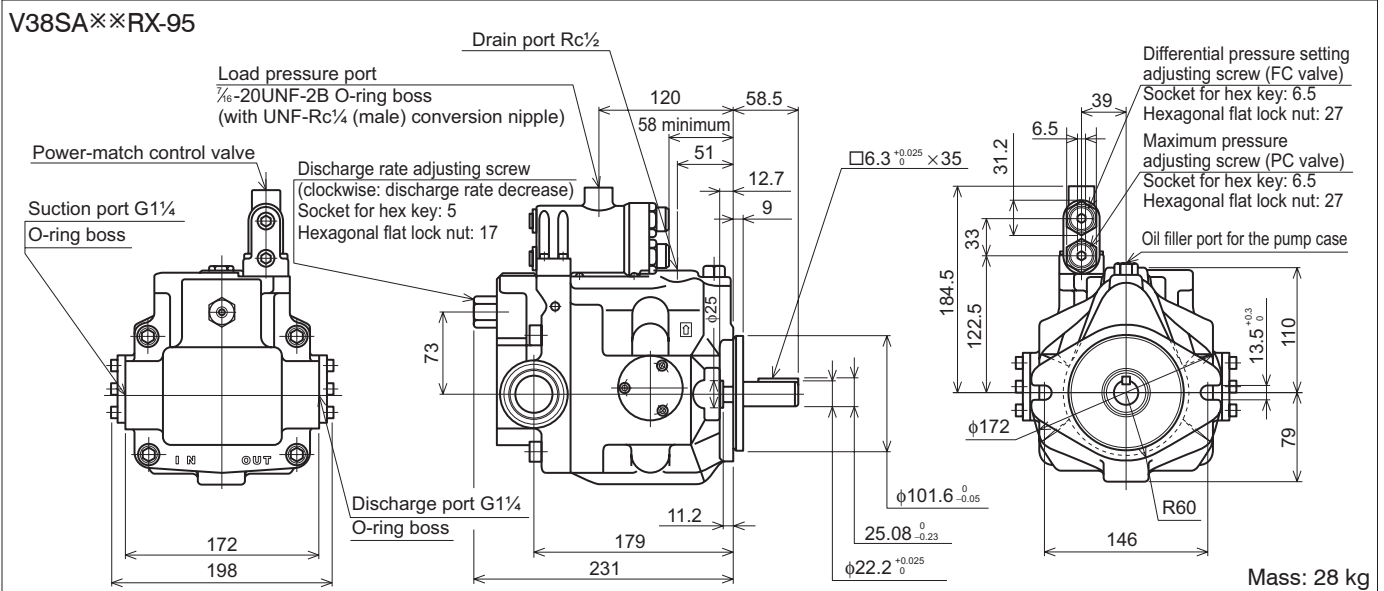

V38SA×R-95

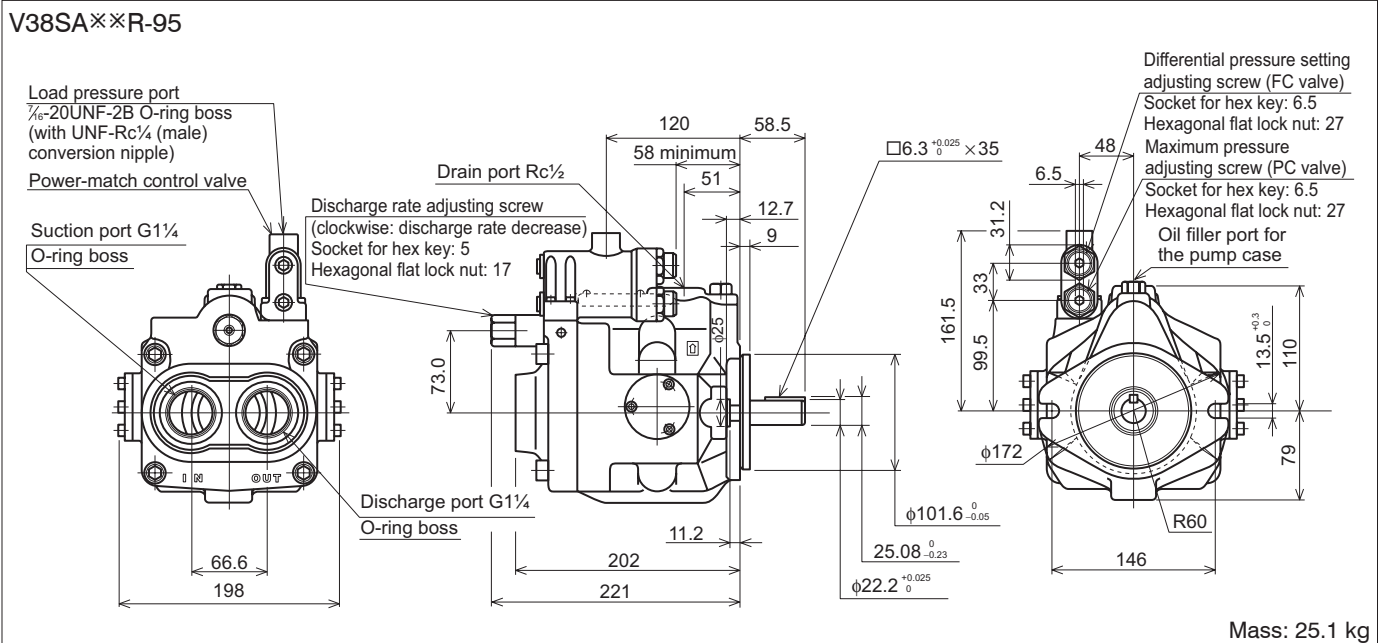

Contact Details

Before using the product, please check the guide pages at the front of this catalog.

Internet

<http://www.daikinpmc.com/en/>

For latest information, PDF catalogs and operation manuals

External dimension diagram

V38SAJS-※RX-95

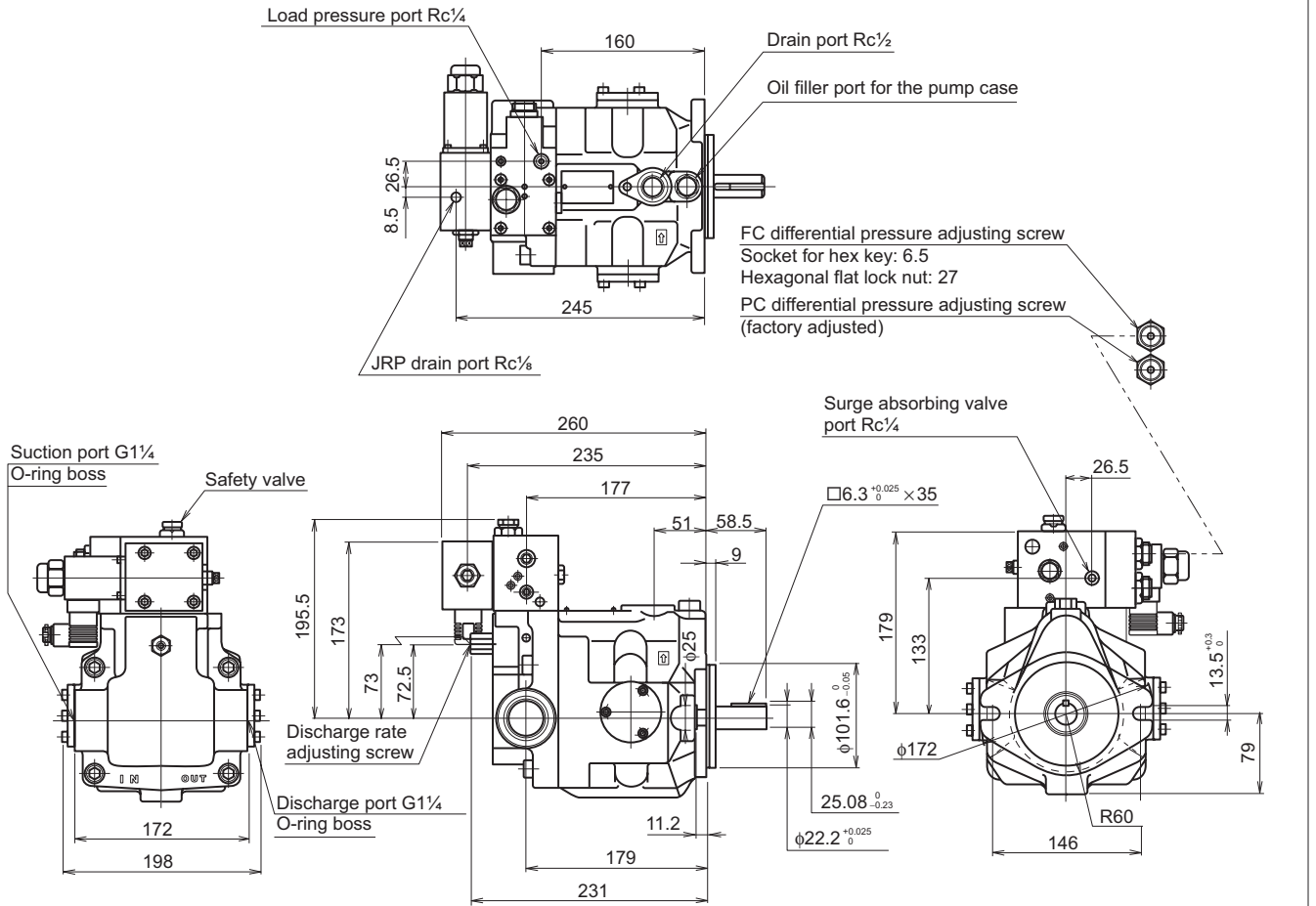

Mass: 32 kg

Contact Details

Before using the product, please check the guide pages at the front of this catalog.

Internet

<http://www.daikinpmc.com/en/>

For latest information, PDF catalogs and operation manuals

External dimension diagram

V50A×RX-20

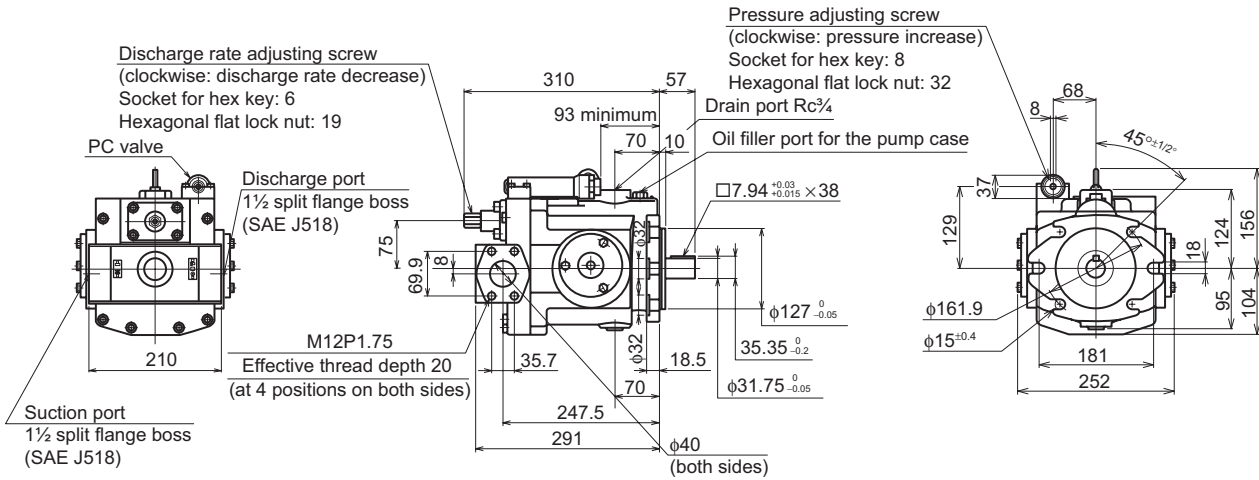

V50A3RX-20RC

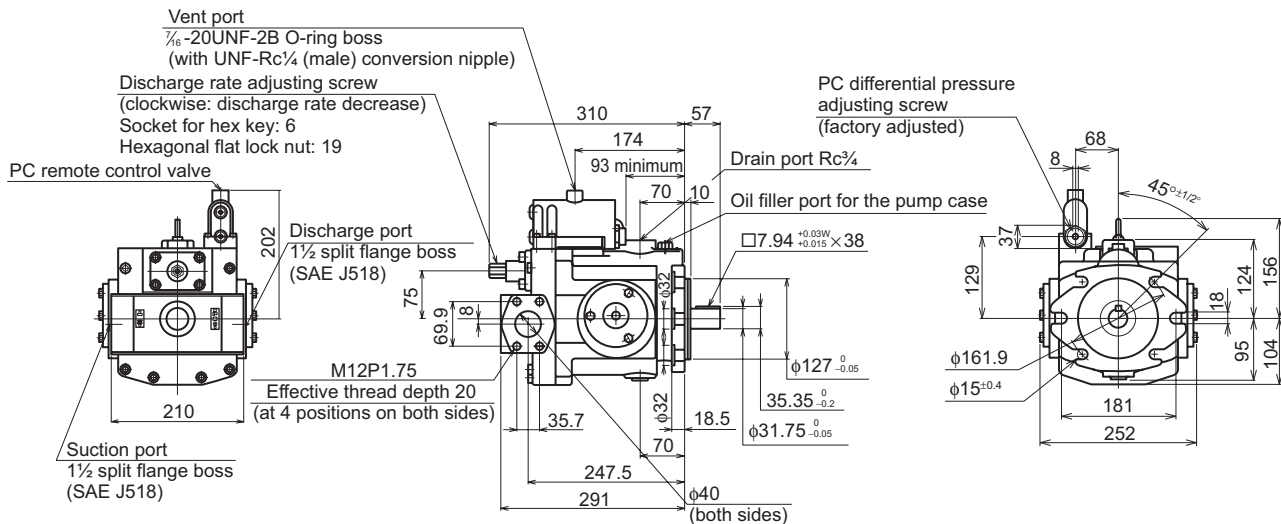

V50SA×RX-20

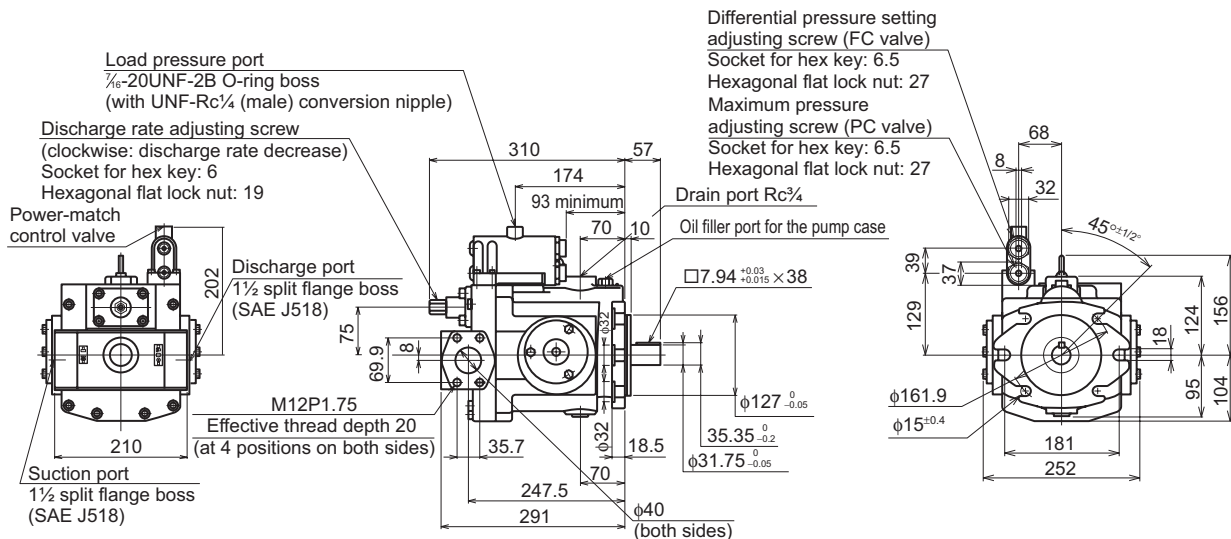

Contact Details

Before using the product, please check the guide pages at the front of this catalog.

Internet

<http://www.daikinpmc.com/en/>

For latest information, PDF catalogs and operation manuals

External dimension diagram

V50SAJS-※RX-20

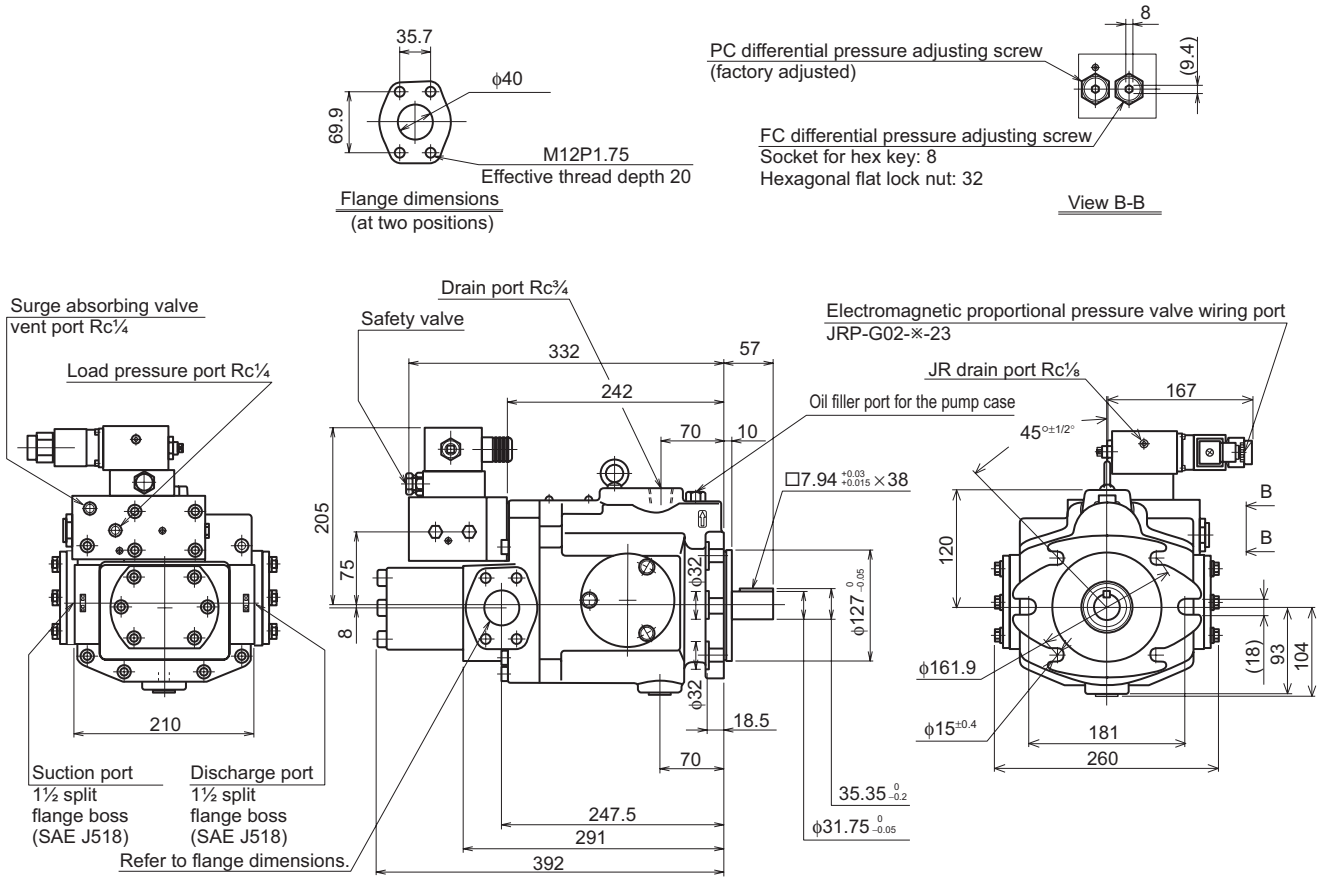

Mass: 69 kg

Contact Details

Before using the product, please check the guide pages at the front of this catalog.

Internet

<http://www.daikinpmc.com/en/>

For latest information, PDF catalogs and operation manuals

External dimension diagram

V70A×RX-60

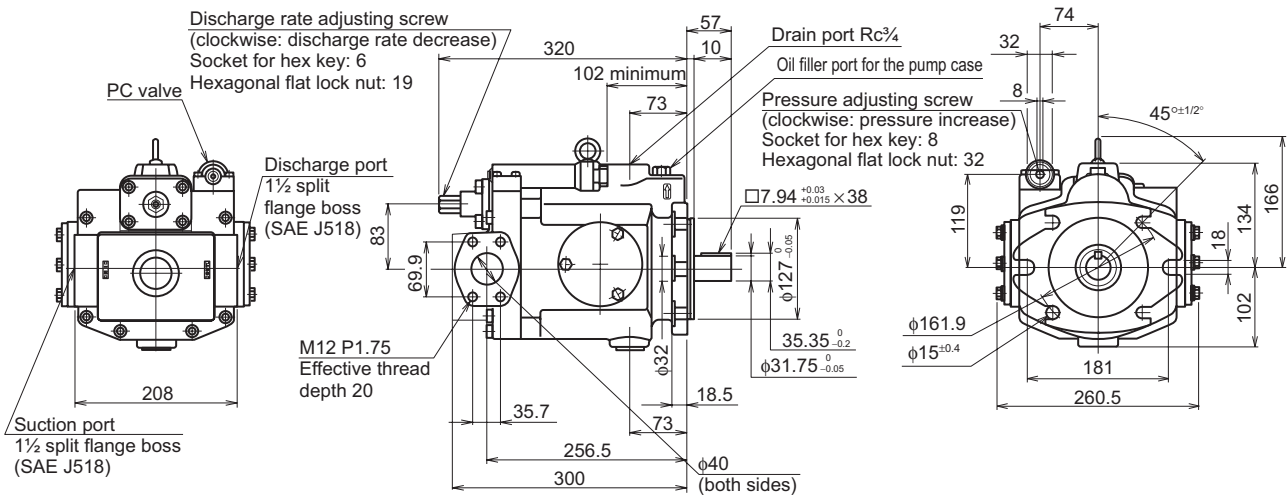

Mass: 55 kg

V70A3RX-60RC

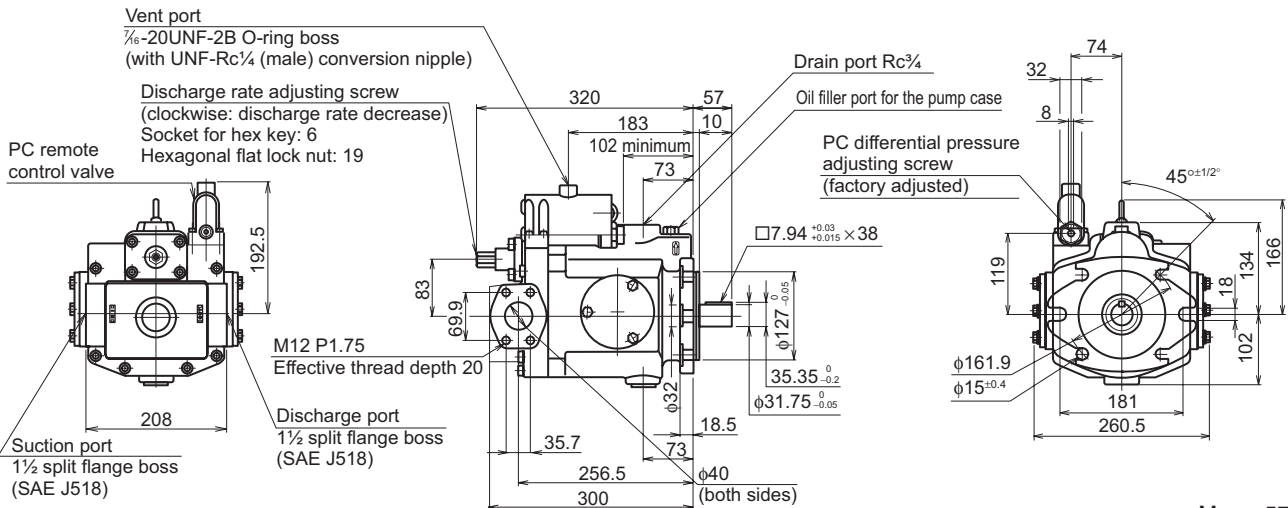

Mass: 57 kg

V70C××RHX-60

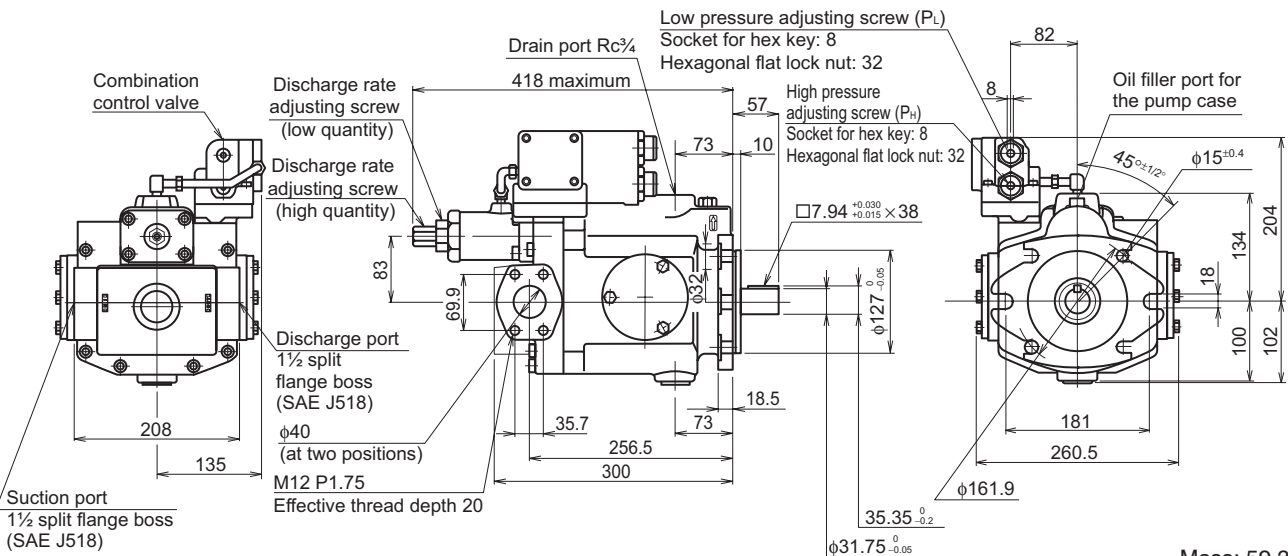

Mass: 59.3 kg

Contact Details

Before using the product, please check the guide pages at the front of this catalog.

Internet

<http://www.daikinpmc.com/en/>

For latest information, PDF catalogs and operation manuals

External dimension diagram

V70SA**RX-60

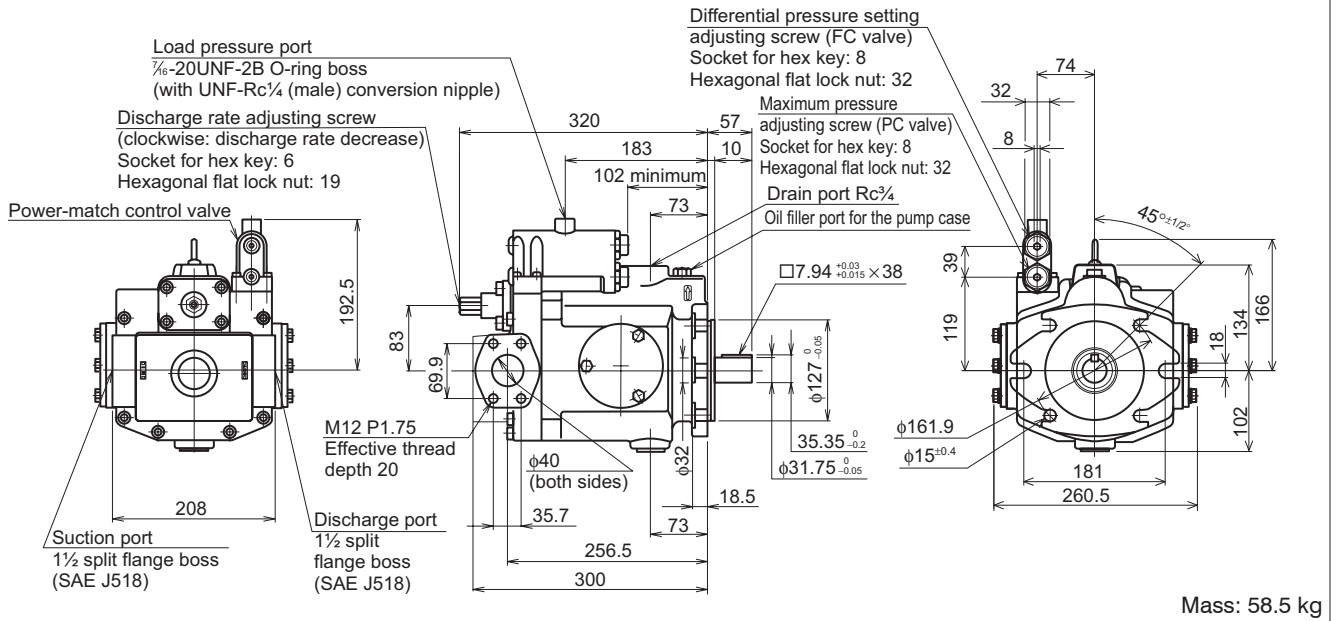

V70SAJS- \times RX-60

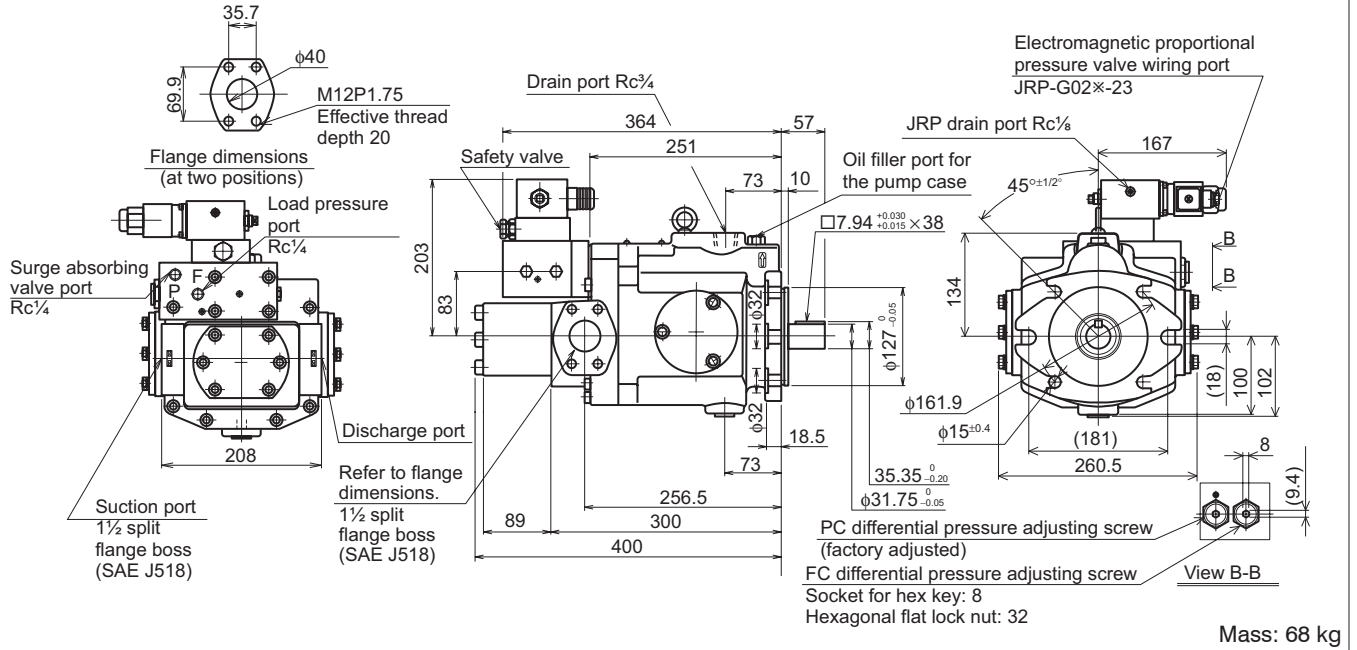

Contact Details

Before using the product, please check the guide pages at the front of this catalog.

Internet

<http://www.daikinpmc.com/en/>

For latest information, PDF catalogs and operation manuals

Sectional structural diagram

V8, V15

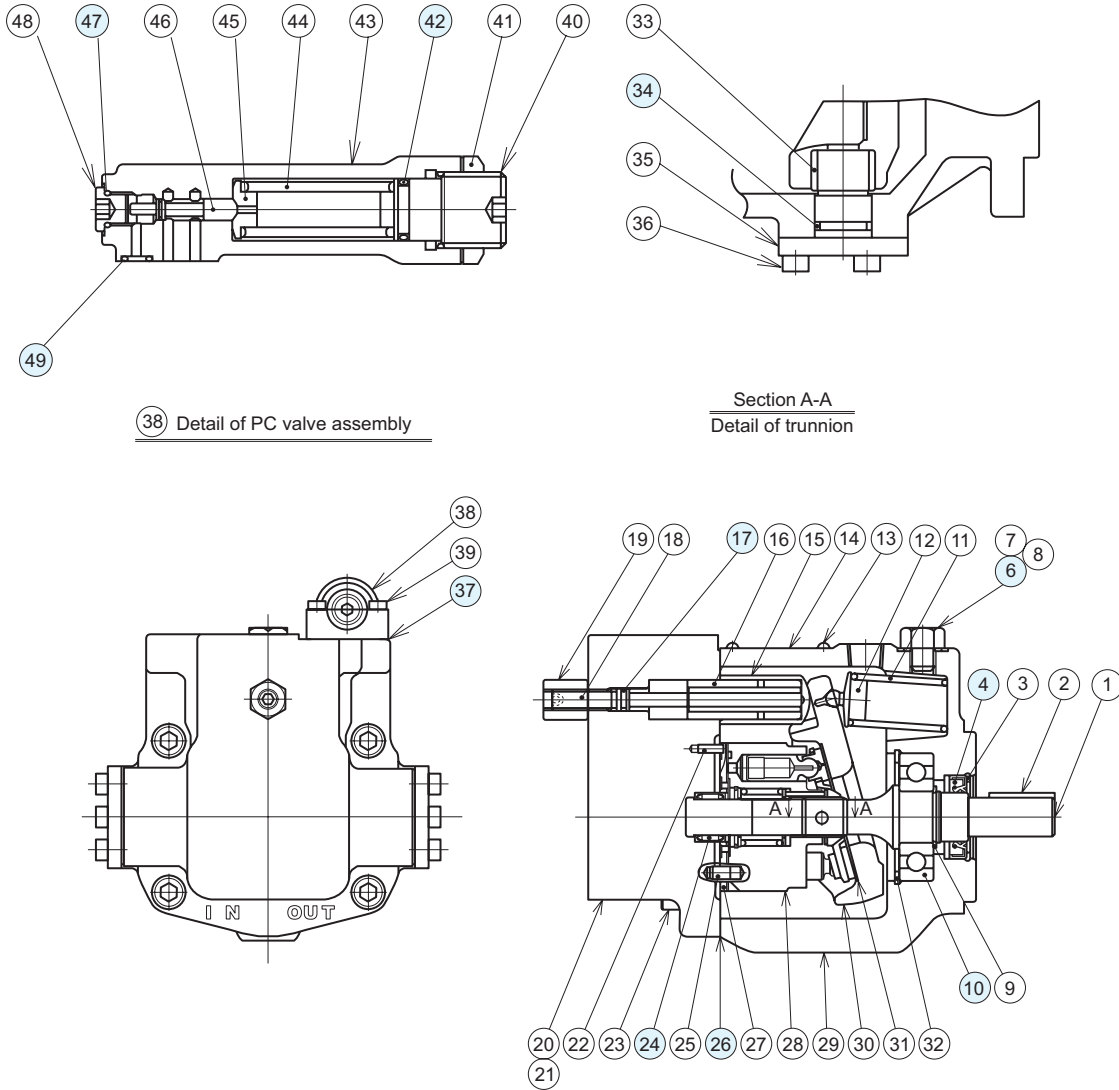

38 Detail of PC valve assembly

Section A-A
Detail of trunion

V8 Seal/bearing table

Part No.	Name	Specifications	Material	Quantity
4	Oil seal	TCV19358	NBR	1
6	Sealing washer	WF12192	NBR	1
10	Ball bearing	6004		1
17	O-ring	JIS B 2401 1A-P4	NBR	1
24	Needle bearing	HK1210		1
26	Gasket	1730500 (special part)		1
34	O-ring	JIS B 2401 1A-P20	NBR	2
37	Gasket	1741116 (special part)		1
42	O-ring	JIS B 2401 1B-P14	NBR	1
47	O-ring	AS568-903 (HS90)	NBR	1
49	O-ring	JIS B 2401 1B-P6	NBR	1

V15 Seal/bearing table

Part No.	Name	Specifications	Material	Quantity
4	Oil seal	TCV24408	NBR	1
6	Sealing washer	WF12192	NBR	1
10	Ball bearing	6305		1
17	O-ring	JIS B 2401 1A-P8	NBR	1
24	Needle bearing	FJL1715		1
26	Gasket	1730390 (special part)		1
34	O-ring	JIS B 2401 1A-P18	NBR	2
37	Gasket	1740698 (special part)		1
42	O-ring	JIS B 2401 1B-P14	NBR	1
47	O-ring	AS568-903 (HS90)	NBR	1
49	O-ring	JIS B 2401 1B-P6	NBR	1

Contact Details

Before using the product, please check the guide pages at the front of this catalog.

Internet

<http://www.daikinpmc.com/en/>

For latest information, PDF catalogs and operation manuals

Sectional structural diagram

V23, V38

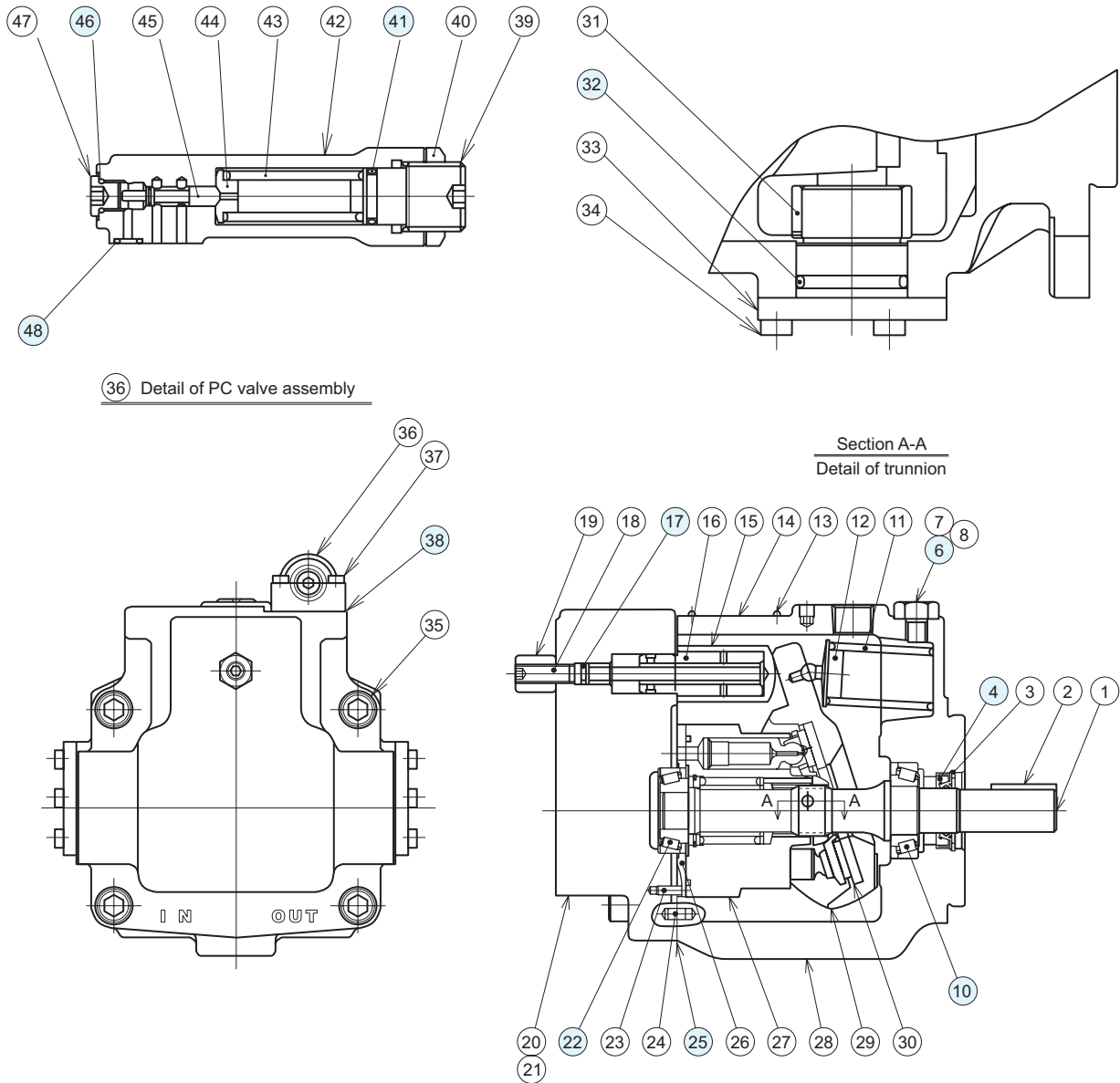

V23 Seal/bearing table

Part No.	Name	Specifications	Material	Quantity
4	Oil seal	TCV24408	NBR	1
6	Sealing washer	WF12192	NBR	1
10	Tapered roller bearing	Cup: 4T-L44610/ Cone: 4T-L44643		1
17	O-ring	JIS B 2401 1A-P8	NBR	1
22	Tapered roller bearing	Cup: 4T- LM11710/ Cone: 4T- LM11749		1
25	Gasket	1730511 (special part)		1
32	O-ring	JIS B 2401 1A-G30	NBR	2
38	Gasket	1740698 (special part)		1
41	O-ring	JIS B 2401 1B-P14	NBR	1
46	O-ring	AS568-903 (HS90)	NBR	1
48	O-ring	JIS B 2401 1B-P6	NBR	1

V38 Seal/bearing table

Part No.	Name	Specifications	Material	Quantity
4	Oil seal	TCV24408	NBR	1
6	Sealing washer	WF12192	NBR	1
10	Tapered roller bearing	Cup: 4T-L44610/ Cone: 4T-L44643		1
17	O-ring	JIS B 2401 1A-P8	NBR	1
22	Tapered roller bearing	Cup: 4T- LM11910/ Cone: 4T- LM11949		1
25	Gasket	1730500 (special part)		1
32	O-ring	JIS B 2401 1A-G30	NBR	2
38	Gasket	1740698 (special part)		1
41	O-ring	JIS B 2401 1B-P14	NBR	1
46	O-ring	AS568-903 (HS90)	NBR	1
48	O-ring	JIS B 2401 1B-P6	NBR	1

Contact Details

Before using the product, please check the guide pages at the front of this catalog.

Internet

<http://www.daikinpmc.com/en/>

For latest information, PDF catalogs and operation manuals

Sectional structural diagram

V50, V70

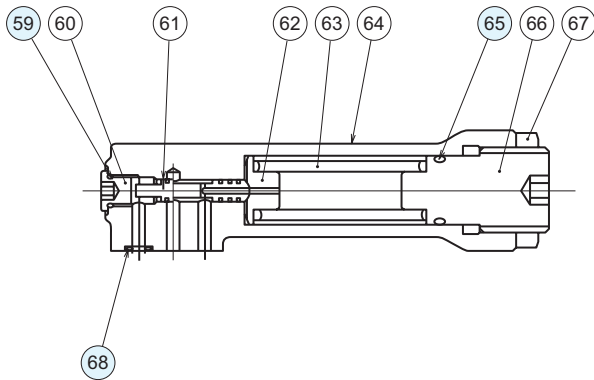

(58) Detail of PC valve assembly

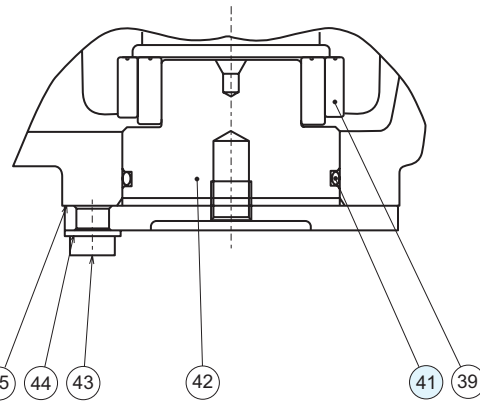

Section A-A
Detail of trunnion

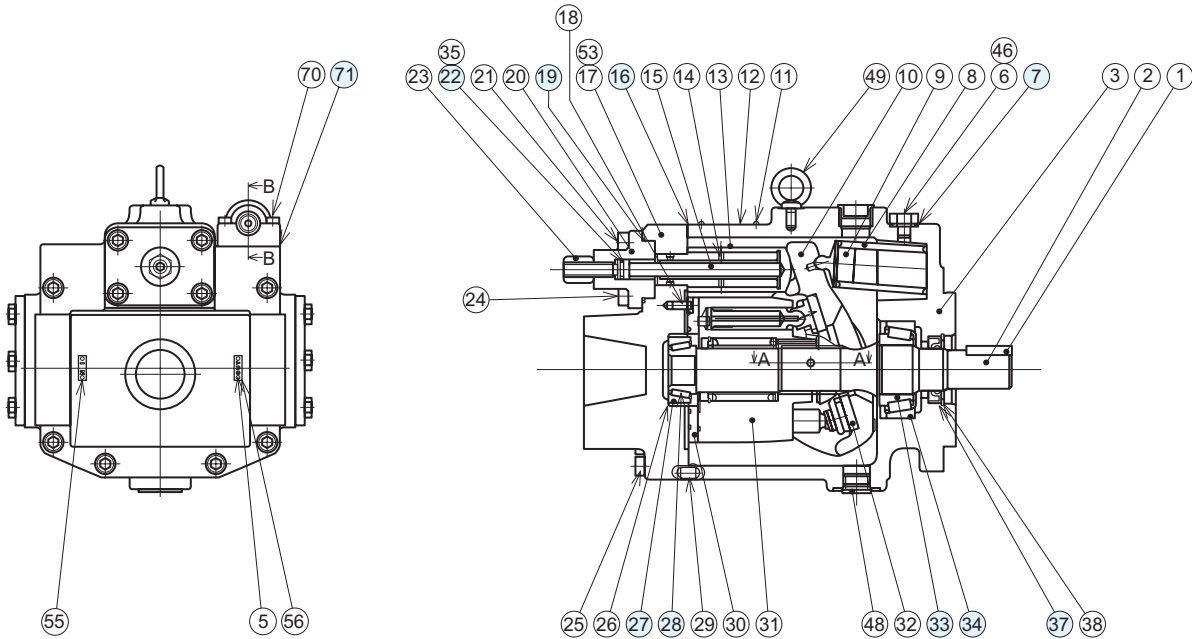

V50 Seal/bearing table

Part No.	Name	Specifications	Material	Quantity
7	Sealing washer	WF12192	NBR	1
16	Gasket	1020257 (special part)		1
19	O-ring	JIS B 2401 1A-G50	NBR	1
22	O-ring	JIS B 2401 1A-P12	NBR	1
27	Tapered roller bearing	Cup: 21212 Sa		1
28	Tapered roller bearing	Cone: 21075 Sa		1
33	Tapered roller bearing	Cone: 4T-344A P × 2		1
34	Tapered roller bearing	Cup: 4T-332 P × 2		1
37	Oil seal	TCV355511	NBR	1
41	O-ring	AS568-228 (HS70)	NBR	2
59	O-ring	AS568-903 (HS90)	NBR	1
65	O-ring	JIS B 2401 1A-P18	NBR	1
68	O-ring	JIS B 2401 1B-P6	NBR	1
71	Gasket	1740975 (special part)		1

V70 Seal/bearing table

Part No.	Name	Specifications	Material	Quantity
7	Sealing washer	WF12192	NBR	1
16	Gasket	1730446 (special part)		1
19	O-ring	JIS B 2401 1A-G50	NBR	1
22	O-ring	JIS B 2401 1A-P12	NBR	1
27	Tapered roller bearing	Cup: 4T-M84210		1
28	Tapered roller bearing	Cone: 4T-M84249		1
33	Tapered roller bearing	Cone: 4T-3386		1
34	Tapered roller bearing	Cup: 4T-3320		1
37	Oil seal	TCV355511	NBR	1
41	O-ring	AS568-230 (HS70)	NBR	2
59	O-ring	AS568-903 (HS90)	NBR	1
65	O-ring	JIS B 2401 1A-P18	NBR	1
68	O-ring	JIS B 2401 1B-P6	NBR	1
71	Gasket	1740975 (special part)		1