



群策電機工業股份有限公司

CHYUN TSEH INDUSTRIAL CO.,LTD

品名 Product Name	油壓感應電動機	型號 Type	HSW	產品編號 Product Number	03043B09270
--------------------	---------	------------	-----	------------------------	-------------

外觀成品圖
Product Appearance

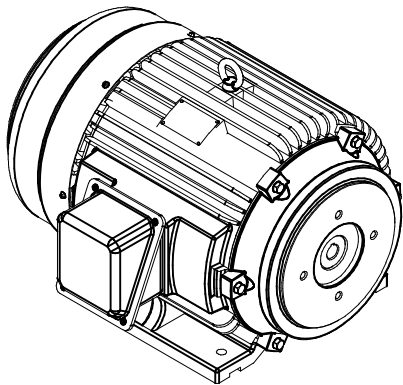

軸心詳圖 Mandrels Detail

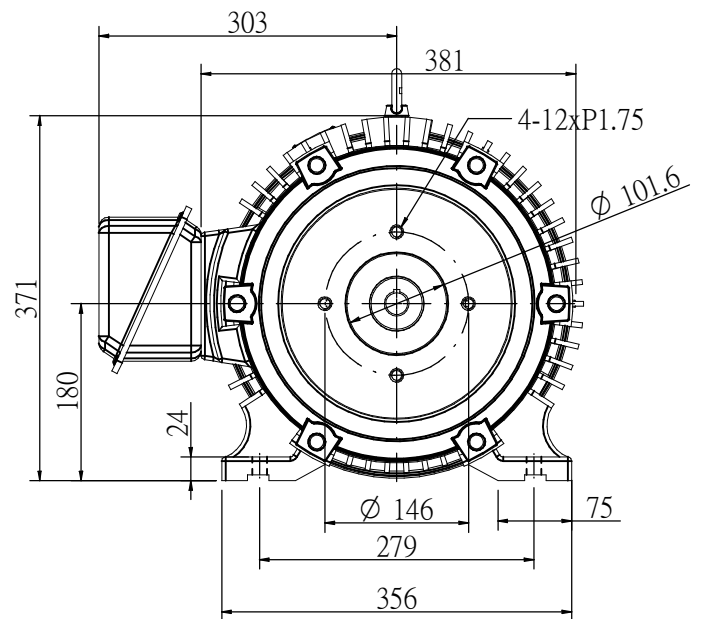
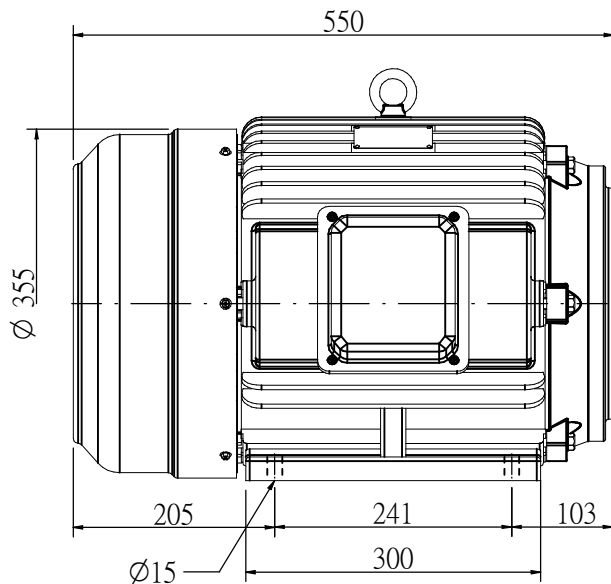
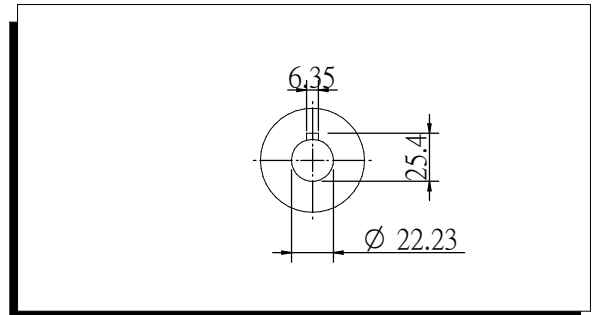

額定輸出 Rated Out Put	30 HP 22 kW	極數 Poles	4 P	相數 Phase	3	框號 Frame No	180MC
馬達型式 Motor Type	銑殼臥式	頻率 Frequency	60 Hz	使用係數 Service Factor	1	防護等級 I. P.	54
滿載轉速 Full Load Speed	1740 R.P.M	幫浦型式 Pump Type	T6C	絕緣等級 Insulation Class	B	運轉 Duty Type	S1
額定電壓 Rated Voltage	220 V	滿載功因% Full Load Power Factor	85.5 %	滿載效率 Full Load Efficiency	89 %	能效等級 IE Code	IE1
滿載電流 Full Load Current	73 A	時間額定 Time Rating	CONT	安裝型式 Mounting Code	B3	接線方式 Wiring	△
溫昇標準 M.A.Temperature	75 C°	前軸承 F Bearing	6311 zz	後軸承 L Bearing	6310 zz	淨重 Weight	220 kg

◎ 本特性表試驗規範依據：IEC60034-2-1及CNS14400 <IE3>

◎ 以上尺寸數值若有變更，恕不另行通知