

Multi-mount cylinder

MK Series

Dimensions

MK

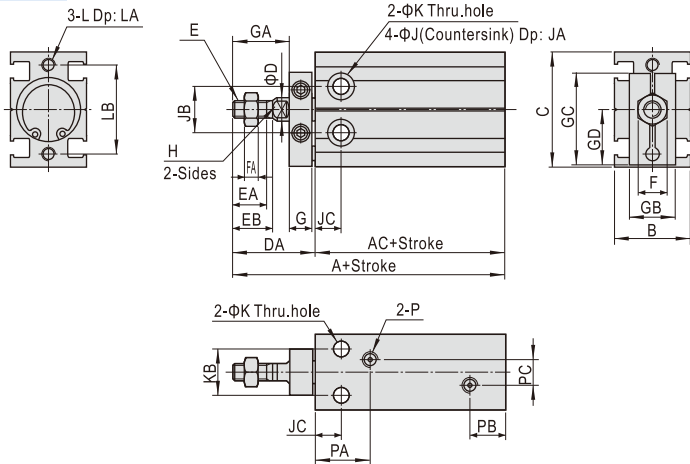

Bore size\Item	Without magnet		With magnet		B	C	D	DA	E
	A	AC	A	AC					
6	51	33	51	33	16.5	22	3	18	M3×0.5
10	57	36	57	36	16.5	24	4	21	M4×0.7
16	56	30	66	40	20	32	6	26	M5×0.8
20	65	36	75	46	26	40	8	29	M6×1.0
25	73	40	83	50	32	50	10	33	M8×1.25
32	84	42	94	52	40	62	12	42	M10×1.25

Bore size\Item	EA	EB	F	FA	G	GA	GB	GC	GD	H	J	JA
6	7	8	5.5	2.5	8	9	11	19	10.9	-	6	5
10	10	11	7	2	8	12	13	20.5	11.9	-	6	5.5
16	11	12.5	8	4	8	17	13	26.5	15.9	5	7.5	6.5
20	12	14	10	5	8	20	16	32	19.8	6	9.5	8
25	15.5	18	12	6	10	22	19	40	24.8	8	9.5	9
32	19.5	22	17	6	12	29	24	49	30.8	10	11	11.5

Bore size\Item	JB	JC	K	KB	L	LA	LB	P	PA	PB	PC
6	10	7	3.3	7	M3×0.5	5	17	M5×0.8	14	10	-
10	11	7	3.3	9	M3×0.5	5	18	M5×0.8	15.5	10	-
16	14	7	4.5	12	M4×0.7	5	25	M5×0.8	14.5	10	3
20	16	9	5.5	16	M5×0.8	7.5	30	M5×0.8	19	9.5	9
25	20	10	5.5	20	M5×0.8	8	38	M5×0.8	21.5	8.5	12
32	24	11	6.5	24	M6×1.0	9	48	1/8"	23	12.5	13

MSK

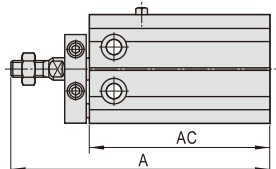

MTK

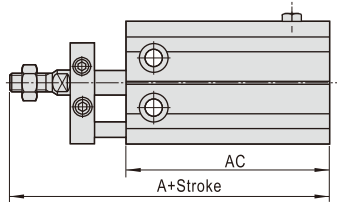

Item	A(Without magnet)				A(With magnet)				AC(Without magnet)				AC(With magnet)			
	5St	10St	15St	20St	5St	10St	15St	20St	5St	10St	15St	20St	5St	10St	15St	20St
6	61	66	76	81	61	66	76	81	43	48	58	63	43	48	58	63
10	67	72	82	87	67	72	82	87	46	51	61	66	46	51	61	66
16	71	76	91	96	81	86	101	106	45	50	65	70	55	60	75	80
20	80	85	100	105	90	95	110	115	51	56	71	76	61	66	81	86
25	88	93	108	113	98	103	118	123	55	60	75	80	65	70	85	90
32	99	104	119	124	109	114	129	134	57	62	77	82	67	72	87	92

Remark) The unmarked dimension is the same as MK standard type.

MKD

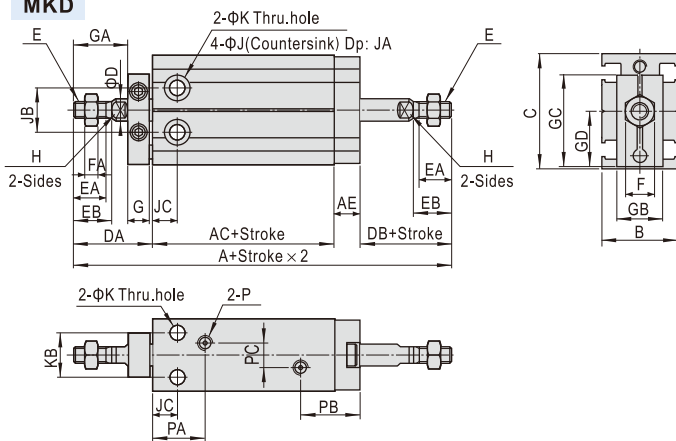

MKJ

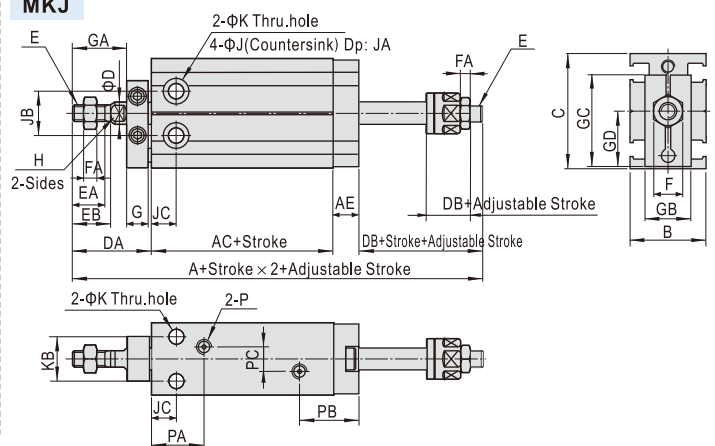

Bore size\Item	A(Without magnet)		A(With magnet)		AC (Without magnet)	AC (With magnet)	AE	B	C	D	DA	DB		E
	MKD	MKJ	MKD	MKJ								MKD	MKJ	
6	75	75	75	75	38	38	6	16.5	22	3	18	13	13	M3×0.5
10	79	78	79	78	36	36	6	16.5	24	4	21	16	14.7	M4×0.7
16	79.5	80.5	89.5	90.5	30	40	7.5	20	32	6	26	16	17	M5×0.8
20	93	95	103	105	36	46	9	26	40	8	29	19	21	M6×1.0
25	105	107	115	117	40	50	9	32	50	10	33	23	25	M8×1.25
32	121	121	131	131	42	52	10	40	62	12	42	27	27	M10×1.25

Bore size\Item	EA	EB	F	FA	G	GA	GB	GC	GD	H	J	JA	JB	JC	K	KB	P	PA	PB	PC
6	7	8	5.5	2.5	8	9	11	19	10.9	-	6	5	10	7	3.3	7	M5×0.8	14	16	-
10	10	11	7	2	8	12	13	20.5	11.9	-	6	5.5	11	7	3.3	9	M5×0.8	15.5	16	-
16	11	12.5	8	4	8	17	13	26.5	15.9	5	7.5	6.5	14	7	4.5	12	M5×0.8	14.5	17.5	3
20	12	14	10	5	8	20	16	32	19.8	6	9.5	8	16	9	5.5	16	M5×0.8	19	18.5	9
25	15.5	18	12	6	10	22	19	40	24.8	8	9.5	9	20	10	5.5	20	M5×0.8	21.5	17.5	12
32	19.5	22	17	6	12	29	24	49	30.8	10	11	11.5	24	11	6.5	24	1/8"	23	22.5	13

